

OLYMPUS OPTICAL CO., LTD.

San-Ei Building, 22-2, Nishi Shinjuku 1-chome, Shinjuku-ku, Tokyo, Japan
Customer support (Japanese language only): Tel. 0426-42-7499 Tokyo

OLYMPUS AMERICA INC.

Two Corporate Center Drive, Melville, NY 11747-3157, U.S.A. Tel. 631-844-5000
(Technical support) Tel. 1-888-553-4448 (Toll-free) (First 30 days after purchase)
Tel. 1-631-844-5520 (After 30 days)
(E-Mail) distec@olympus.com

Olympus software updates can be obtained at: <http://olympus.com/digital/>

Adobe [Photoshop] Support

Adobe software updates and technical information can be obtained at:
<http://www.adobe.com/support/>

OLYMPUS OPTICAL CO. (EUROPA) GMBH.

(Premises/Goods delivery) Wendenstraße 14-18, 20097 Hamburg, Germany Tel. 040-237730
(Letters) Postfach 10 49 08, 20034 Hamburg, Germany
Our Hotline is available from 9 am to 6 pm (Monday to Friday)
E-Mail: dl.support@olympus-europa.com

«Olympus Web site» <http://www.olympus.com>

Thank you for purchasing an Olympus digital camera. This guide has been designed for those who want to become familiar with the camera in a very short time. See the Reference Manual for more details.

Checking the Package Contents

- | | |
|---|--|
| <input type="checkbox"/> Camera | <input type="checkbox"/> Warranty/Registration card (North America only) |
| <input type="checkbox"/> Strap | <input type="checkbox"/> Safety Precautions |
| <input type="checkbox"/> Lens cap with string | <input type="checkbox"/> SmartMedia (16 MB) |
| <input type="checkbox"/> USB cable | <input type="checkbox"/> Static free case for SmartMedia |
| <input type="checkbox"/> AA (R6) alkaline batteries (4) | <input type="checkbox"/> Labels for SmartMedia (2 pieces) |
| <input type="checkbox"/> CD-ROMs with Windows 98 USB driver software, Reference manual, and more. | <input type="checkbox"/> Write-protect seals for SmartMedia (4 pieces) |
| <input type="checkbox"/> Basic Manual | <input type="checkbox"/> SmartMedia Instructions |
| <input checked="" type="checkbox"/> Quick Start Guide (this publication) | |
| <input type="checkbox"/> Software installation guide (included in the CD-ROM package in some areas) | |

Attaching the strap

- 1 Pull the string loop through the hole in the lens cap.



- 2 Put the strap through the string loop.

- 3 Thread the strap through the strap eyelet.

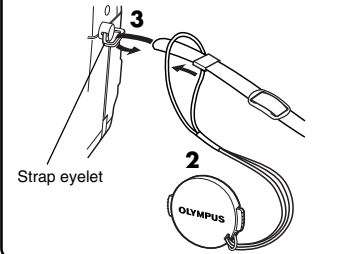

- 4 Loosen the strap in the stopper beforehand to adjust the strap length.

- 5 Thread the strap through the stopper as indicated by the arrows. When the strap length is satisfactory, pull on the strap to make sure it is securely fastened.

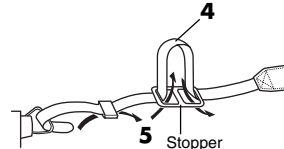

- 6 Attach the strap to the other strap eyelet following steps 3 - 5.

Loading the batteries

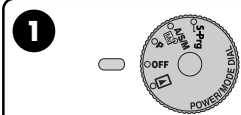

- 1 Make sure the camera is turned off (i.e. the mode dial is set to OFF).

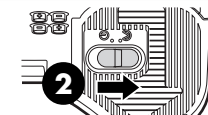

- 2 Slide the battery compartment lock on the battery compartment cover in the direction of ↺.

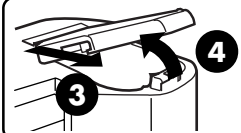

- 4 Slide the battery compartment cover in the direction of the arrow printed on it, using your fingertip. Using a fingernail could result in injury.

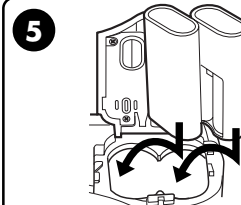

When using LB-01 lithium battery packs When using AA (R6) batteries

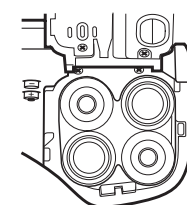

- 5 Insert the batteries in the direction shown in the illustration.

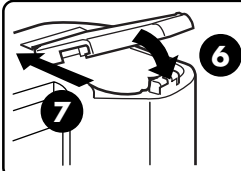

- 6 Close the battery compartment cover, then press it down and slide it in the opposite direction of the arrow printed on it.

- When pressing the battery compartment cover shut, be sure to press the center of the cover, as it may be difficult to close properly by pressing the edge.
- Make sure the cover is completely closed.

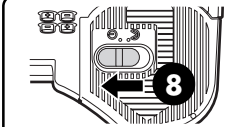

- 8 Slide the battery compartment lock on the battery compartment cover in the direction of ↻.

Inserting/ejecting the card



- 1 Make sure the camera is turned off (i.e. the mode dial is set to OFF).

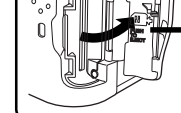

- 2 Open the Card cover.

Inserting the card

- 3 Insert the card fully with the contact area facing towards the monitor side (back of the camera). Insert until you feel the card locked into place.

- Note the orientation of the card. If it is inserted incorrectly, it may become jammed.

Ejecting the card

- 3 Push in the card lightly to unlock it, then pull it out.

- 4 Close the cover tightly.

Note:

- NEVER open the card cover, eject the card, remove the batteries, or disconnect the optional AC adapter while the camera is in use or the camera is communicating with a computer. Doing so could destroy all data on the card.

Taking still pictures

Full Automatic mode

- 1 Remove the lens cap and set the mode dial to P.

- 2 Point the camera towards a subject while viewing through the viewfinder.

- 3 To focus on the subject, press the shutter button halfway, slowly and gently.

- When the subject is in focus, the green lamp lights up.

- 4 To start shooting, press the shutter button gently all the way (fully).

- The green lamp and card access lamp blink and the camera begins storing pictures on the card.

- To turn off the camera
Set the mode dial to OFF.

Viewing still pictures

Quick View

- 1 Press the (monitor) button twice quickly.

- The monitor turns on and the recorded picture appears.

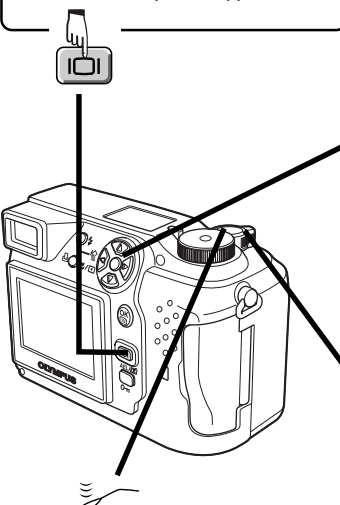

- 3 To return to the shooting mode, press the shutter button halfway.

- The monitor turns off. You can now shoot pictures using the viewfinder.

- 2 Display the desired pictures using the arrow pad.

- Pictures indicated by are movie frames. → See "Playing back movies".

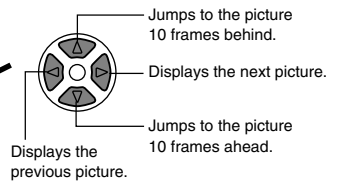

- Turning the zoom lever towards
- T: Enlarges the picture.
 - W: Displays multiple pictures at the same time.

Recording movies

Movie mode

- 2 Press to display Menu.

- 3 Press to select S-Prg.

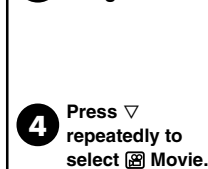

- 4 Press repeatedly to select Movie.

- 5 Press .

- 6 Point the camera towards the subject and compose the picture while viewing through the monitor.

- 1 Remove the lens cap and set the mode dial to S-Prg.

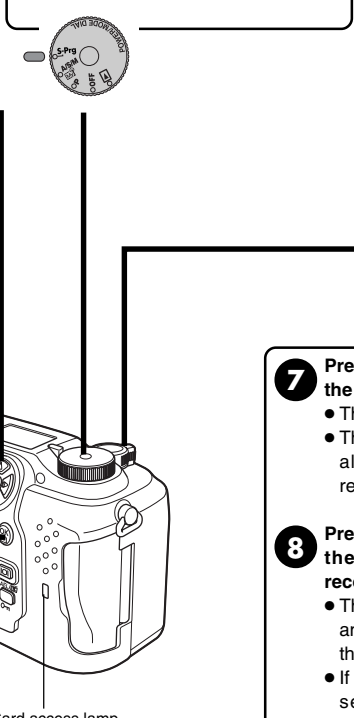

- 7 Press the shutter button all the way to start recording.

- The orange lamp lights up.
- The subjects are kept in focus all the time during movie recording.

- 8 Press the shutter button all the way again to stop recording.

- The card access lamp blinks and the camera starts writing the movie to the card.
- If you use up the remaining seconds displayed, the camera automatically stops shooting and starts writing the movie to the card.

Playing back movies

Quick View

- 1 Display the movie frame (picture with ) you want to play back. → See steps 1 and 2 in "Viewing still pictures".

- 2 Press  to display Menu.

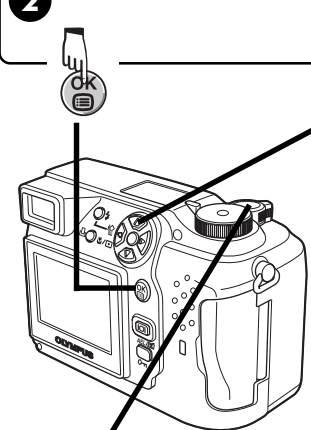

- 3 Press  on the arrow pad to select MOVIE PLAY.

- The card access lamp blinks while movie data is accessed. The camera starts playing back after loading the movie data.

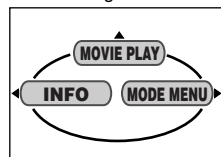

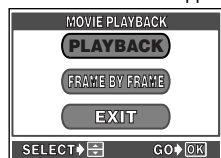

- When playback finishes, the screen returns to the beginning of the movie.
- If you press  again, the MOVIE PLAYBACK screen appears.



- 4 To return to the shooting mode, press the shutter button halfway.

- The monitor turns off. Shoot pictures using the viewfinder.

Select an item displayed on the screen by pressing  or  on the arrow pad, and then press  to start one of following operations.

PLAYBACK: Plays back the entire movie again.

FRAME BY FRAME: Plays back the movie manually by one frame at a time.

EXIT: Leaves the movie playback mode.

Erasing pictures



Single-frame erase

- 1 Display the picture you want to erase. → See steps 1 and 2 in "Viewing still pictures".

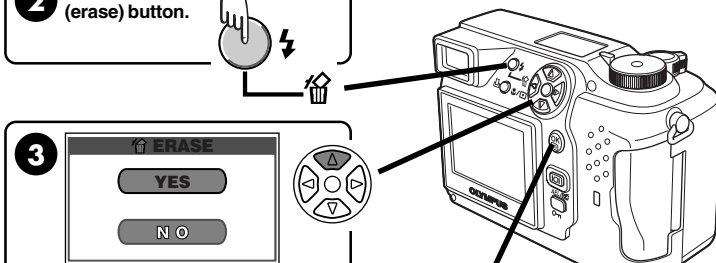
- 2 Press the  (erase) button.



When the  ERASE screen appears, press  to select YES.

- To cancel erasure, press  on the arrow pad to select NO, and press  or the  button.

- 4 Press  to erase the picture.

Using the zoom

Shoot a wider picture (wide-angle)

Press the zoom lever toward W to zoom out.



Zoom in on a subject (telephoto)

Press the zoom lever toward T to zoom in.

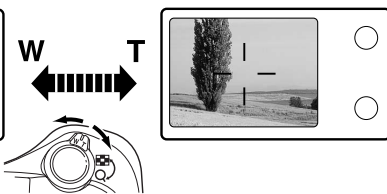

How to use the menu functions

Moving around the menu screen

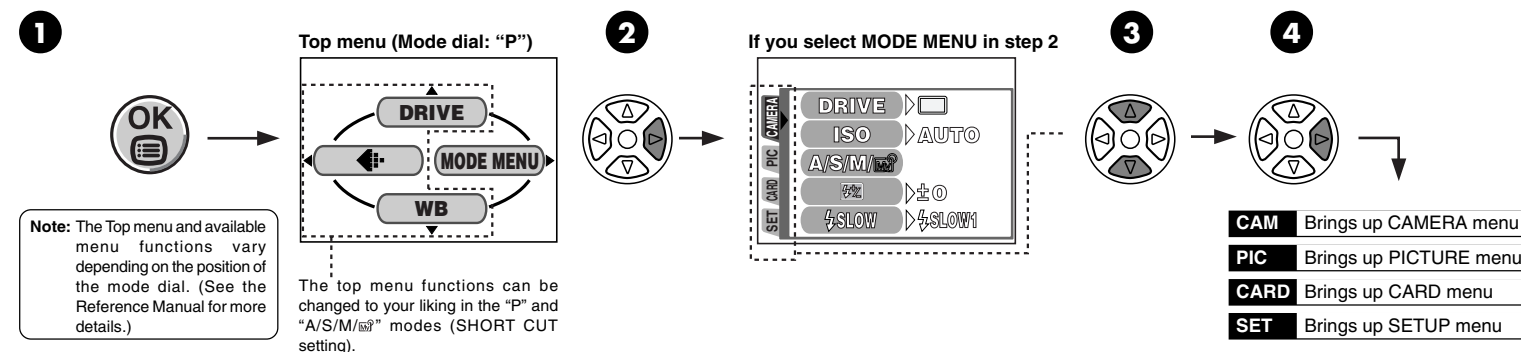



Menu functions for shooting operation

CAMERA

DRIVE	Selects the drive mode from sequential shooting, auto bracketting, or self-timer shooting.
ISO	Selects the ISO sensitivity. (AUTO/100/200/400)
A/S/M/☺	Selects the exposure mode from A (Aperture priority auto), S (Shutter priority auto), M (Manual mode), or ☺ (My mode setup) when the Mode dial is set to "A/S/M/☺".
	Adjusts the flash intensity for different shooting conditions.
1/2 SLOW	Adjusts the flash for slow shutter speeds. (1/2 SLOW1/1/2 SLOW/1/2 SLOW2)
NOISE REDUCTION	Reduces the noise on images during long exposures.
DIGITAL ZOOM	Zooming can be set up to 7.5x in combination with the optical 3x zooming (equivalent to 32 mm-96 mm on a 35 mm camera).
FULLTIME AF	Keeps the image in focus at all times without having to press the shutter button halfway.
AF MODE	Selects the auto focus mode (iESP or SPOT).
PANORAMA	The Olympus standard SmartMedia card (supplied) allows you to combine pictures side by side. (*CAMELIA Master is required.)
FUNCTION	Lets you shoot pictures in black & white or sepia tone, etc.



PICTURE

	Sets the record mode. (TIFF/SHQ/HQ/SQ)
WB	Adjusts the white balance according to the light source. (AUTO/PRESET/☺)
	Allows you to make fine changes to the white balance manually.
SHARPNESS	Adjusts the sharpness of images.
CONTRAST	Adjusts the contrast of images.

CARD

CARD SETUP | Formats SmartMedia cards.

SETUP

ALL RESET	Selects whether to keep the current camera settings when you turn off the power.
	Sets the beep sound to OFF/LOW/HIGH.
REC VIEW	Selects whether to display images on the monitor while saving them to a card.
MY MODE SETUP	Enables you to customize the settings of menu functions to your preference and save the set of the settings as the ☺ shooting mode.
FILE NAME	Creates file/folder names for images to be saved. (RESET/ AUTO)
	Adjusts the brightness of the monitor.
	Sets the date/time.
m/ft	Sets the measurement units (m/ft) used during manual focus.
SHORT CUT	Selects functions for the shortcut menu on the top menu screen.
CUSTOM BUTTON	Lets you assign a function to the custom button on the camera (factory default setting: AE lock).

Menu functions for playback operation

(still pictures)

Runs through all saved pictures one after another (slide-show).

MOVIE PLAY (movies)

Plays back movies.

INFO

Changes the amount of shooting information (ISO, White Balance, etc.) displayed on the Monitor.





ROTATE (still pictures)

Changes the orientation of the played back picture among three angles. (-90°/+90°/0°)

CARD

CARD SETUP | Formats SmartMedia cards (FORMAT), or erases all images in the card (ALL ERASE).

SETUP

ALL RESET	Selects whether to keep the current camera settings when you turn off the power.
	Sets the beep sound to OFF/LOW/HIGH.
	Adjusts the brightness of the monitor.
	Sets the date/time.
	Selects the number of frames in the index display. (4/9/16-frame)

How to use the buttons and dial

Buttons and dial

Zoom lever

Shooting : Zooms in/out.
Playback : Displays multiple pictures at the same time (Index-display), or enlarges pictures (close-up playback).
Print reserve : Sets trimming size.

Shutter button

Focuses (half press) or shoots (full press).

Mode dial

S-Prg : Scene program shooting
A/S/M/☺ : Sets controls for Aperture-priority auto exposure/Shutter-priority auto exposure/Manual exposure/My mode setup shooting.
P : Full automatic exposure with one press of the shutter button.
OFF : Turns off the power.
 : Displays pictures.

Macro/Spot button

Shooting : **Macro**
 — Takes close-up pictures (Working range: 0.2-0.8 m (0.6-2.6 ft)).
Spot
 — Selects area for metering.
Playback : Selects pictures for printing (Print reserve).

Flash mode button

Shooting : Selects flash modes (Working range
 → Wide : 0.8-3.6 m (2.6-11.8 ft)
 Tele: 0.2-3.6 m (0.6-11.8 ft)
Playback : Each press erases one frame.

Arrow pad

Menu screen : Selects menu items.
Shooting : Sets aperture/shutter speed/exposure compensation/manual focusing values.
Playback : Selects pictures to be displayed.

OK/Menu button

- Displays menu screen.
- Sets selected items on the menu screen.
- Hold down for one second or more to put the camera into manual focus mode.

Viewfinder

Monitor

Shooting : Displays the shooting object.
Playback : Displays the recorded images.

Monitor button

- Turns the monitor on/off.
- Press quickly twice to play back the last recorded image.

AE lock/Custom button

Shooting : **AE lock** (factory default setting)
 — Locks exposure.
Custom button
 — Performs whichever function you have set for it.
Playback : Protects pictures from being accidentally erased.