

# MINOLTA

## VECTIS 20

### E INSTRUCTION MANUAL



Thank you for purchasing the Minolta Vectis 20. The Vectis 20 is an IX240 type compact camera from Minolta's new lineup of Advanced Photo System™ cameras. Designed with simplicity and reliability in mind, your camera features a 2X zoom, drop-in loading, and date imprinting. The 2X zoom lens, autofocus, and auto exposure systems will let you handle virtually any photographic situation, and the built in front cover will help protect the camera's optics when the camera is not in use. This manual has been designed to help you understand the operation of your camera and its functions. Please familiarize yourself with the names of the controls and their locations on the camera, then read this manual thoroughly.

#### New print formats...

Classic C print, wider H print, and panorama P print formats are available with Advanced Photo System cameras.

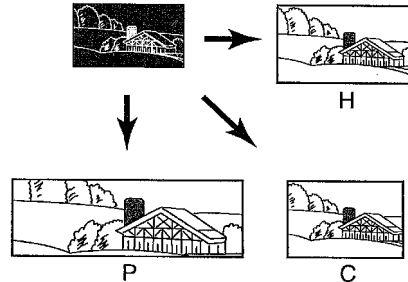

#### Advantages of the Advanced Photo System

##### Easier to load...

Advanced Photo System cameras use the new IX240 type film. This new film features drop-in-loading to make loading your camera simple, the first time, every time. Indicators on the cassette tell you and your camera if the film is unexposed, partially exposed, exposed, or processed.

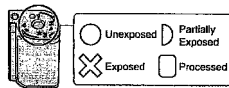

##### New processing...

In addition to returning your prints in the format you selected, certified photofinishers will return your Advanced Photo System film in its original cassette with an index print. To order reprints, simply choose the images you want from the index print. No more searching through negatives to find the right frame.

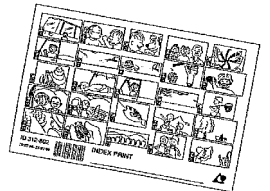

• Advanced Photo System™ is a trademark of the five system developing companies, including Minolta.

## FOR PROPER AND SAFE USE

Read and understand all warnings and cautions before using this product.



### WARNING

Batteries may become hot or explode due to improper use.

- Use only the batteries specified in this instruction manual.
- Do not install the batteries with the polarity (+/-) reversed.
- Do not subject batteries to fire or high temperatures.
- Do not attempt to recharge, short, or disassemble.
- Tape over lithium battery contacts before disposal. Follow local codes for battery disposal.

Use caution, accidents may occur when using this product near young children.

Keep batteries or things that could be swallowed away from young children. Contact a doctor immediately if an object is swallowed.

Immediately remove the batteries and discontinue use if...

- the camera is dropped or subjected to an impact in which the interior is exposed.
- the product emits a strange smell, heat, or smoke.

The lens retracts when the camera is turned off or Auto Power Off is activated. Touching the lens barrel while it is retracting may cause injury.

Do not disassemble. Electric shock may occur if a high voltage circuit inside the camera is touched. Take your camera to a Minolta Service Facility when repairs are required.

### OPERATING TEMPERATURE AND CONDITIONS

- This camera is designed for use from -10° to 40° C (14° to 104° F).
- Never leave your camera where it may be subjected to extreme temperatures such as the glove compartment of a car.
- At colder temperatures, the data panel response time will be slow. At higher temperatures, the display will temporarily darken, but will restore when the temperature normalizes.
- Never subject the camera to extreme humidity.
- Do not let the camera get wet or allow sand or grit to get into the camera, this could result in costly or irreparable damage
- To prevent condensation from forming, place the camera in a sealed plastic bag when bringing it from the cold exterior into a warm building. Allow it to come to room temperature before removing it from the bag.
- When photographing in cold weather, we recommend that you keep the camera and spare batteries inside your coat to keep them warm when you are not shooting. Cold batteries will regain some of their charge when they warm up.

### FILM CASSETTE WARNING

The film used in Advanced Photo System cameras stores some data magnetically. Do not place the film cassette on or near anything that creates a magnetic field, such as a television or stereo speakers.

### CAMERA ERROR

If the data panel is blank and the camera will not function with fresh batteries, remove and reinsert the batteries. If normal operation does not resume, or the camera malfunctions repeatedly, contact an authorized Minolta Service Facility.



This mark on the bottom of your camera is there to inform you that this camera meets the requirements of the EU (European Union) concerning interference causing equipment regulations. CE stands for Conformité Européenne (European Conformity).

## NAMES OF PARTS

### BODY

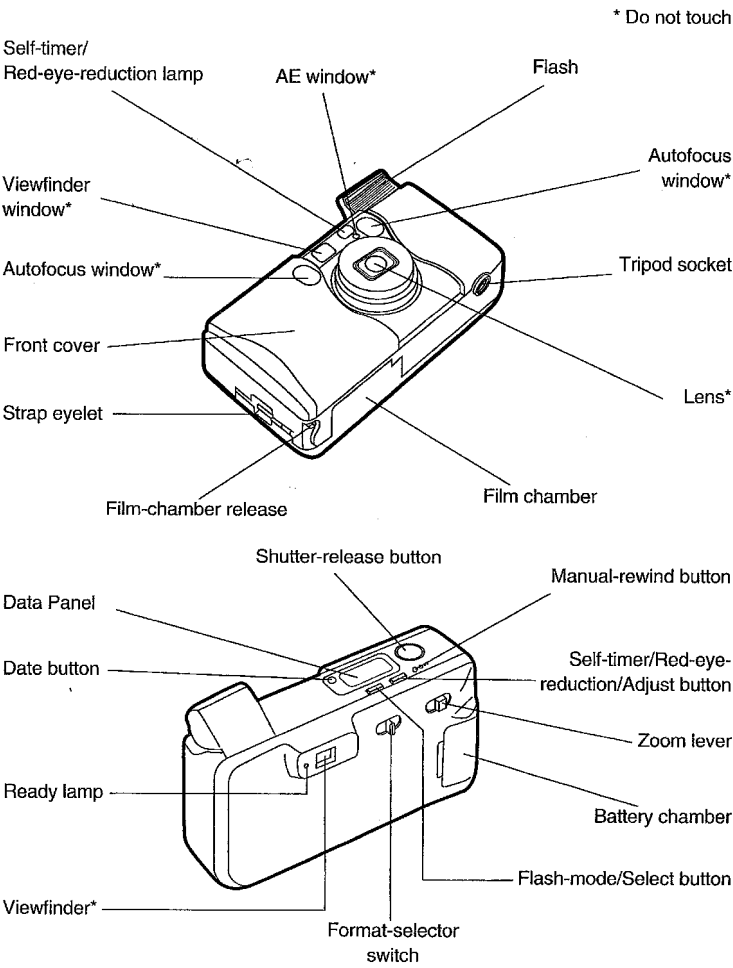

### DATA PANEL

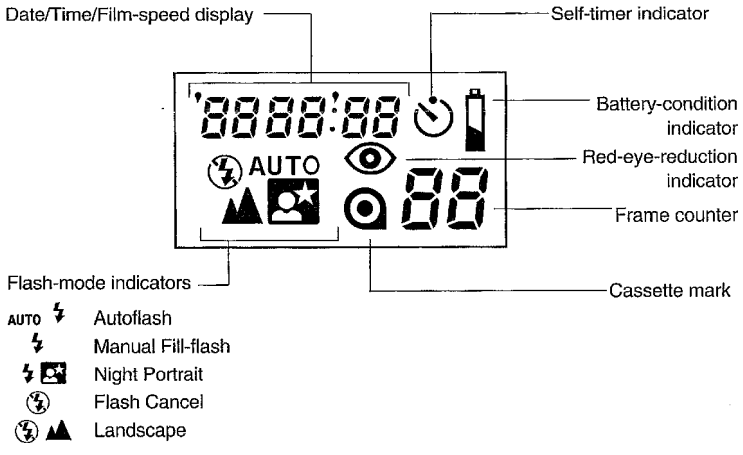

### VIEWFINDER

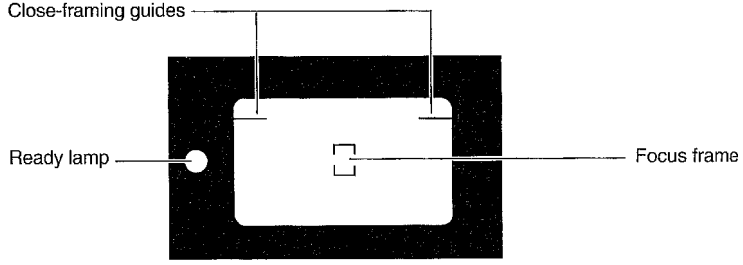

### ATTACHING THE STRAP

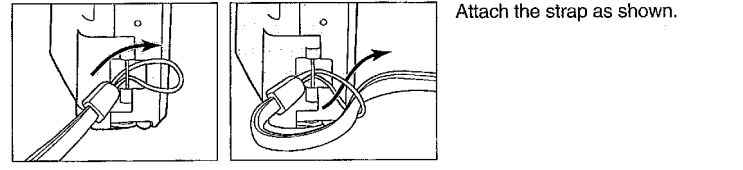

## INSTALLING THE BATTERY

Your camera uses one 3-volt CR2 lithium battery to supply power for all camera operations. Please read all warnings in the Safety Cautions section of this manual as well as those supplied by the battery manufacturer.

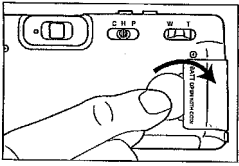

1. Using a coin, open the battery-chamber door.

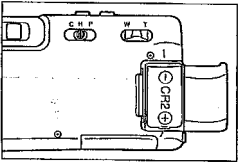

2. Insert the battery into the chamber as indicated by the + and - marks.

3. Close the battery-chamber door.

- After installing a new battery, reset the date and time.

## CHECKING THE BATTERY POWER

### Blinking low-battery indicator

Power is sufficient for all camera operations, but is getting low. Keep a new battery handy.

### No data appears in the data panel

Replace the battery or check that it is inserted correctly.

- To save power, your camera will shut down if it is not operated for more than three minutes.

## LOADING FILM

Your camera uses IX240 type film designed for use in Advanced Photo System cameras.

- Your camera is equipped with an automatic transport system which loads the film, sets the film speed, and advances the film after each exposure.
- There is no need to worry about double exposure. DEP (Double Exposure Prevention) prevents the camera from accepting exposed film.
- Do not open the film chamber unless a 0, a blinking 0, or a blinking E is seen in the data panel.

## VISUAL EXPOSURE INDICATORS (VEI)

- The current VEI has a white indicator behind it.

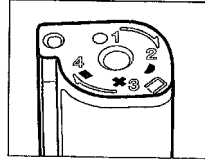

VEI	MEANING
●	UNEXPOSED
▶	PARTIALLY EXPOSED
✕	EXPOSED
■	PROCESSED

- This camera can only load film cassettes with the ● mark current.

## LOADING THE FILM

1. Turn the camera upside down and slide the film-chamber release in the direction shown.

- The film-chamber door will open.

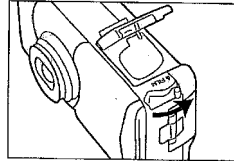

2. Insert the new film cassette into the film chamber with the VEI on top.

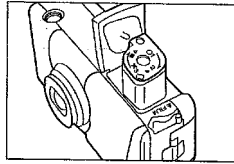

3. Close the film-chamber door as shown.

- The camera will automatically advance the film to the first frame.

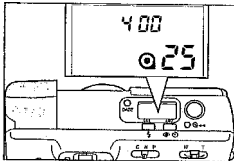
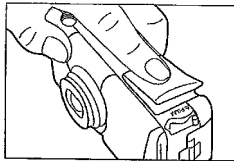

- 0 and the number of frames remaining on the roll will be displayed in the data panel.
- Film can be loaded with the power off.
- If film is loaded with the power off, after the number of frames remaining on the roll is displayed, all indicators will disappear.

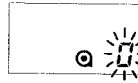

- If 0 blinks in the data panel, open the film chamber and remove the film cassette.
  - Your camera can not load a film cassette if the current VEI is ▶, ✕, or ■.
  - If a processed (VEI ■) or partially exposed (VEI ▶) film cassette was loaded into this camera, the VEI has been changed to ✕.
- If all indicators blink in the data panel, remove and reload the film. If the film will not load, contact the nearest authorized Minolta Service Facility.

## FULL AUTO OPERATION

### 1. Open the front cover to turn the camera on.

- The flash is set to autoflash and will fire when necessary.

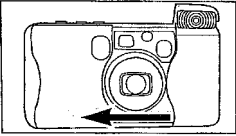

### 2. Select the print format. The viewfinder will change to match your selection.

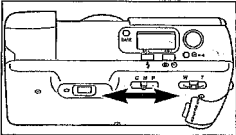

Hold the camera steady, making sure your fingers do not cover the flash. If you are taking a vertically framed picture, turn the camera so the flash is on top.



### 3. Looking through the viewfinder, frame the subject as desired.

Press **W** on the zoom lever to zoom out.  
Press **T** on the zoom lever to zoom in.

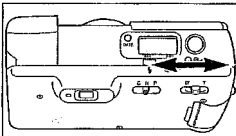

### 4. Center your subject in the focus frame (□), then press the shutter-release button partway down.



### 5. When the ready-lamp glows, press the shutter-release button all-the-way down to take the picture.

- When the ready-lamp blinks slowly, turn the flash on, or mount the camera on a tripod
- When the ready-lamp blinks quickly, the camera is too close to the subject
- Press the shutter with a slow steady squeeze, never a quick jab.

### 6. To turn the camera off, slide the front cover closed and push the flash down.

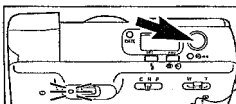

## FOR CLOSER SUBJECTS

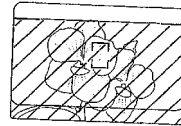

When your subject is closer than 60cm (2 ft.), align the top of your image with the close-framing guides, using focus hold if necessary.

Print Format	C and H Formats		P Format	
	WIDE	TELE	WIDE	TELE
Focal Length				
Focus Range	0.55m - ∞ (1.8 ft. - ∞)	0.4m - ∞ (1.3 ft. - ∞)	0.65m - ∞ (2.13 ft. - ∞)	1.2m - ∞ (4.3 ft. - ∞)

## FOCUS HOLD



If your subject is outside of the focus frame, it may not be in focus. Use focus hold to ensure accurate focusing.

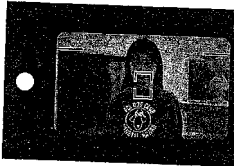

1. Center your subject in the focus frame.
  2. Press and hold the shutter-release button partway down until the ready-lamp glows.
- Focus hold also locks the exposure.



3. Without lifting your finger, re-compose the picture and press the shutter-release button all-the-way down to take the picture.
- Lift your finger from the shutter-release button to cancel focus hold.

## USING THE BUILT-IN FLASH

When you turn the camera on, autoflash mode is set. In this mode, the flash fires automatically in low-light situations.



### READY LAMP

- Wait until the ready-lamp glows, then take the picture.
- The flash takes approximately 3.5 seconds to charge.

### FLASH RANGE

The range of the built-in flash depends on the film speed and the focal length you are using. To ensure proper exposure, make sure your subject is positioned within the flash range.

Focal Length	ISO 200
WIDE	0.55~ 5.3m (1.8~17.4 ft.)
TELE	0.4 ~ 3.1m (1.3~10.2 ft.)

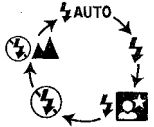

### SELECTING THE FLASH MODE

Besides autoflash mode, manual fill-flash, flash-cancel, and night-portrait modes can be selected. Red-eye reduction can be used in any of these flash modes.

Press the flash-mode button until the desired indicator appears in the data panel.

- Flash modes remain selected after you take the picture.



### MANUAL FILL-FLASH

The flash will fire when the shutter is released regardless of lighting. Use manual fill-flash to illuminate a backlit subject, or to reduce harsh shadows on your subject's face.

Press the flash-mode button until  appears in the data panel.

### NIGHT PORTRAIT

Night-portrait mode balances the flash and existing light exposure so you can take beautiful pictures of people at sunset or at night.

Press the flash-mode button until  and  appear in the data panel.

- The shutter speed will most likely be slow. Use of a tripod is recommended.

### FLASH CANCEL



Use flash cancel when photographing twilight scenes or to capture the ambiance of existing light.

Press the flash-mode button until  appears in the data panel.

- The shutter speed may be slow when the flash is canceled. Use of a tripod is recommended.

### LANDSCAPE

Use the landscape mode to photograph distant scenes beyond the range of the flash.

Press the flash-mode button until  and  appear in the data panel.

- The shutter speed may be slow when the flash is canceled. Use of a tripod is recommended.

## DATE/TIME IMPRINTING

Your camera uses the film's magnetic data strip to record date and time information your photofinisher can imprint on the front and back of your photographs.

- Some labs can not imprint on the front of your photographs. See your photofinisher for a full description of available services.
- Date and time information is always recorded on the film's magnetic data strip.
- Your camera has an automatic calendar through the year 2029.

### IMPRINTING THE DATE OR TIME

**Before taking the picture:**  
Press the date button until the data you want printed on the front of the print appears.

- The sequence is as follows:  
DATE → TIME → — (no imprinting)

- The selected date/time mode will remain on until another mode is selected.

### CHANGING THE DATE AND TIME INFORMATION

1. Open the front cover to turn the camera on.
2. Press and hold the date button until the year blinks in the data panel.

- Only the date will be displayed in the data panel.

3. Press the adjust button to change the blinking item.

- Press and hold the adjust button to change the value rapidly.

4. Press the select button to choose the next item to adjust.

- The sequence is as follows:  
YY → MM → DD → HH → MM

- Time is displayed and imprinted in 24-hour format.

5. When all items in the display are correct, press the select button until the standard display returns.

### CHANGING THE DATE/TIME FORMAT

1. Close the front cover to turn the camera off.

2. Press the date button until the date display blinks in the data panel.

3. Press the adjust button to change the date format.

- The format sequences as follows:  
YMD → MDY → DMY

4. Press the date button to set the selected format.

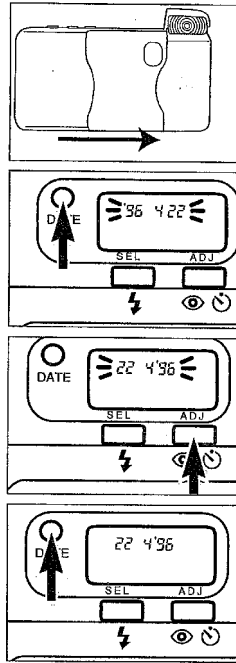

### SELF-TIMER

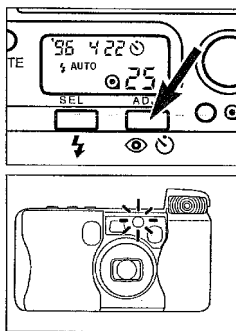

The self-timer delays release of the shutter for approximately 10 seconds after you press the shutter-release button.

1. Place the camera on a tripod and press the red-eye-reduction/self-timer button until the self-timer icon appears in the data panel.
2. Center your subject in the focus frame.
3. Press the shutter-release button all-the-way down.

- The self-timer indicator on the front of the camera blinks slowly during countdown, then glows steadily just before the shutter releases.

- The self-timer is automatically canceled after the shutter releases or the camera is turned off.
- To cancel the self-timer before the picture is taken, press the red-eye-reduction/self-timer button, or turn the camera off.
- Do not press the shutter-release button while standing in front of the camera.
- If you want to take a picture with your subject outside of the focus frame, use focus hold.

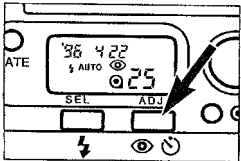

### RED-EYE REDUCTION

When photographing people or animals at night or other low-light situations, light reflecting off the inside of the subjects eyes may produce the effect called red-eye. To reduce this effect, use the red-eye-reduction flash mode in auto, manual-fill, and night-portrait flash modes.

Press the self-timer/red-eye-reduction button until  appears in the data panel.

- Warn your subject(s) that the red-eye-reduction lamp on the front of the camera will illuminate before the picture is taken.

## REWINDING THE FILM

### AUTOMATIC REWIND

The camera automatically rewinds the film into the cassette after the last exposure.

**1. Wait for the film to completely rewind into the cassette.**

- The frame counter will count down during rewind.
-  will blink in the data panel when the film is rewind.

**2. Turn the camera upside down and slide the film-chamber release in the direction shown to open the film-chamber door.**

**3. Remove the film cassette.**

- The current VEI will be **X**.

### MANUAL REWIND

Use manual rewind to rewind the film before the roll is finished.

**1. Gently press the manual-rewind button using a pen or similar object.**

**2. Follow steps 1- 3 from automatic rewind.**

- If the film-chamber door is opened before the film is rewind, rewind will stop. Rewind will continue when the film-chamber door is closed.

## LAB SERVICES



To receive the best possible prints, take your film to a photofinisher displaying the Certified Advanced Photo System Photofinishing Service logo. Photofinishers displaying this logo have been certified according to Advanced Photo System guidelines.

- The following is a list of services required for certification, see your photofinisher for a full list of available services.

Photofinishers displaying this logo are able to provide the following five services.

#### 1. CHP - Print Format

Your film will be printed according to the format set when the picture was taken.

#### 2. Date Imprinting

The date or time will be printed on the back of the picture in the chosen format.

#### 3. PQI - Print Quality Improvement

The lab will compensate (or not compensate) printing according to the data recorded onto the IX data strips.

#### 4. Film is returned in the cassette.

To keep the film dust free and aid in organization, film will be returned in its original cassette and the VEI set to  to prevent accidental loading.

#### 5. Index Print

An index print showing a numbered image of each frame is included with your returned order.

### REPRINTS

Images are always captured in the H Print format. However, any of the three formats can be selected when ordering reprints.

## TECHNICAL DETAILS

<b>Camera Type:</b>	IX240 Lens Shutter Type
<b>Lens:</b>	30 to 60mm f/4.0 7 elements/7 group construction Maximum Magnification: 1/5.7 X Type: Real-image zoom Magnification: 0.35 - 0.67X
<b>Viewfinder:</b>	
<b>Focusing Range:</b>	
<b>Wide/Tele in H and C:</b>	0.55m - ∞/0.4m - ∞
<b>Wide/Tele in P:</b>	0.65m - ∞/1.2m - ∞
<b>Film Speed Range:</b>	ISO 100 - 800
<b>Metering Range (ISO 200):</b>	
<b>WIDE:</b>	EV 6.0-16
<b>TELE:</b>	EV 7.8-16
<b>Flash Range(ISO 200):</b>	
<b>WIDE:</b>	0.55~ 5.3m (1.8~17.4 ft.)
<b>TELE:</b>	0.4 ~ 3.1m (1.3~10.2 ft.)
<b>Battery:</b>	One CR2 3V lithium battery Battery-condition indication: 2-stage indication Battery performance: approximately 15 rolls with 25 exposures
<b>Dimensions:</b>	113.5 x 59 x 37.5mm
(W x H x D)	4.47 x 2.32 x 1.48 in.
<b>Weight:</b>	170g

Specifications are based on the latest information available at the time of printing and are subject to change without notice.

This device complies with Part 15 of the FCC Rules. Operation is subject to the following two conditions: (1) This device may not cause harmful interference, and (2) this device must accept any interference received, including interference that may cause undesired operation. Changes or modifications not approved by the party responsible for compliance could void the user's authority to operate the equipment. This equipment has been tested and found to comply with the limits for a Class B digital device, pursuant to Part 15 of the FCC Rules. These limits are designed to provide reasonable protection against harmful interference in a residential installation. This equipment generates, uses and can radiate radio frequency energy and, if not installed and used in accordance with the instructions, may cause harmful interference to radio communications. However, there is no guarantee that interference will not occur in a particular installation. If this equipment does cause harmful interference to radio or television reception, which can be determined by turning the equipment off and on, the user is encouraged to try to correct the interference by one or more of the following measures:

- Reorient or relocate the receiving antenna.
- Increase the separation between the equipment and the receiver.
- Connect the equipment to an outlet on a circuit different from that to which the receiver is connected.
- Consult the dealer or an experienced radio/TV technician for help.

This Class B digital apparatus meets all requirements of the Canadian Interference-Causing Equipment Regulations.

## CARING FOR YOUR CAMERA

### Cleaning

- Keep the AF and AE windows clean or the focus and/or exposure may not be accurate
- If the camera body is dirty, gently wipe it clean with a soft, dry cloth.
- To clean the lens surface, first brush away any dust or sand then, if necessary, moisten a lens tissue with lens cleaning fluid and gently wipe the lens in a circular motion, starting from the center.
- Never place lens fluid directly on the lens.
- Never touch the lens surface with your fingers.
- Never use alcohol or solvents to clean the camera.

### Storage

When storing the camera for extended periods of time, please follow these guidelines.

- Store the camera in a cool, dry, well-ventilated area away from dust and chemicals. For very long periods, place the camera in an airtight container with a silica gel drying agent.
- Before using after prolonged storage, check the camera's operation to make sure it is functioning properly.

### Before Important Events

- Always check camera operation carefully, or take test photographs.
- Minolta is not responsible for damages incurred by equipment malfunction.

### Questions and Service

- If you have questions about your camera, contact your local camera dealer or write to the Minolta distributor in your area.
- Do not open the film chamber or forcefully remove the cassette if the film cannot be rewound. Contact an authorized Minolta Service Facility.
- Before shipping your camera for repair, contact an authorized Minolta Service Facility for details.

#### Minolta Co. Ltd.

Minolta GmbH  
Minolta France S.A.  
Minolta (UK) Limited  
Minolta Austria Ges. m.b.H.  
Minolta Camera Benelux B.V.  
    Belgium Branch  
Minolta (Schweiz) AG  
Minolta Svenska AB  
    Finland Branch  
Minolta Portugal Limitada  
Minolta Corporation  
    Head Office  
    Los Angeles Branch  
Minolta Canada Inc.  
    Head Office  
    Vancouver Branch  
Minolta Hong Kong Limited  
Minolta Singapore (Pte) Ltd.  
Shanghai Minolta Optical  
Products Co., Ltd.

3-13, 2-Chome, Azuchi-Machi, Chuo-Ku, Osaka 541-8556, Japan

Kurt-Fischer-Strasse 50, 22923 Ahrensburg, Germany  
365 Route de Saint-Germain, F-78420 Carrières-Sur-Seine, France  
Rooksley Park, Precodent Drive, Rooksley, Milton Keynes, MK13 8HF, England  
Amalienstrasse 59-61, 1131 Wien, Austria  
P.O. Box 6000, NL-3600 HA MAARSSEN, The Netherlands  
Konfichsesleenweg 38, B-2630 Aartselaar, Belgium  
Riedstrasse 6 8953 Dietikon, Switzerland  
P.O.Box 9058 Albygatan 114 S-17109 Solna, Sweden  
Niittykatu 6 PL 37 SF-02201 Espoo, Finland  
Av. do Brasil 33-A, P-1700 Lisboa, Portugal

101 Williams Drive, Ramsey, New Jersey 07446, U.S.A.  
11150 Hope Street Cypress, CA 90630, U.S.A.

369 Britannia Road East, Mississauga, Ontario L4Z 2H5, Canada  
230-3771 Jacobs Road, Richmond, B.C. V6V 2L9, Canada  
Room 208, 2/F, Eastern Center, 1065 King's Road, Quarry Bay, Hong Kong, China  
10, Teban Gardens Crescent, Singapore 608923

70 Zhong Shan Road (E), Song Jiang County, Shanghai, China

© 1996 Minolta Co., Ltd. under the Berne Convention and  
Universal Copyright Convention

9222-2203-31 P-E801  
Printed in Japan