

DRIVE – Exposure Bracketing

Exposure bracketing automatically exposes a series of frames with exposures above and below the metered exposure value. Bracket your exposures when shooting slides and other films with a low tolerance for exposure error.

- This camera can expose a 3, 5, or 7 frame brackets in increments of 0.3, 0.5, 0.7, or 1.0 EV.
- A larger bracketing increment is recommended when shooting negative film.

Manual (M) and aperture priority (A) mode exposures are bracketed by changing the shutter speed.

Shutter priority (S) mode exposures are bracketed by changing the aperture.

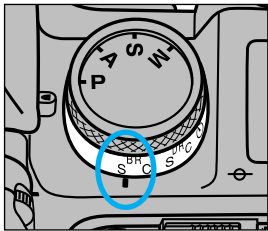

1. Turn the drive-mode lever to the desired bracketing mode.

S – Single Frame Advance
C – Continuous Advance

2. Open the control panel, then press the adjust button.

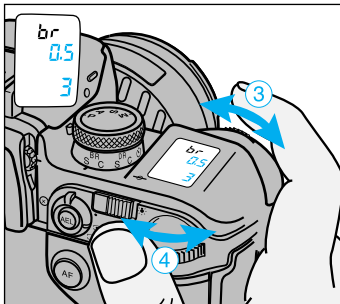

3. Turn the front control dial to set the bracketing increment (0.3, 0.5, 0.7, or 1.0 EV).

4. Turn the rear control dial to set the size of the bracket (3, 5 or 7 frames).

5. Press the shutter-release button partway down to enter the settings.

- *br 1* appears in the data panel when single frame advance is selected.

6. Compose and meter your subject, then press the shutter-release button all the way down to start the bracket.

- Exposure is locked on the first frame of the series.
- The exposure setting changes automatically.
- Press the AE-lock button when the shutter is released to bracket using the aperture in M-Mode.

Bracketing Notes

Continuous – Hold the shutter-release button down until the series is finished.

- Removing your finger from the shutter-release button before the series is complete resets the camera to the first frame of the bracket.
- Continuous advance bracketing is cancelled at the end of the roll.

Single – Press the shutter-release button for each exposure.

- *br 1*, *br 2*, *br 3* ... will be displayed in the frame counter.
- Film can be changed in the middle of the bracketed series.
- Turn the main switch to LOCK or select another drive mode to cancel single frame advance bracketing.

Custom Function Notes

cust 11 Switch to setting 2 to change the bracketing sequence to under exposures, metered exposure, over exposures (p.97).

DRIVE

DRIVE — Multiple Exposure



The multiple exposure function makes it possible to expose 2 or more images on the same frame.

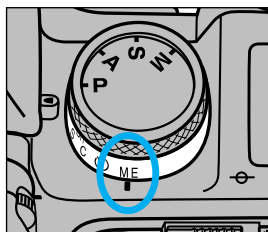

1. Turn the drive-mode lever to ME.

- *ME* appears in the frame counter.

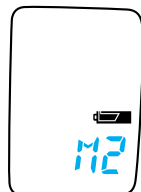

2. Compose the scene, then press the shutter-release button all the way down to take the first exposure.

- *M2* appears in the data panel after the first exposure is taken.

3. Take additional exposures as desired.

- Additional exposures are counted only up to *M3*, but an unlimited number of exposures can be taken.

4. Select another drive mode to cancel multiple exposure mode and advance the film to the next frame.

Metering Multiple Exposures

The meter in your camera determines exposure (EV) based on the assumption that only one exposure will be made on each frame. When making multiple exposures, the EV for each additional exposure needs to be reduced or over exposure will result.

- Compensation is not necessary if all of the exposures have dark backgrounds and the subjects of the exposures will not overlap.

Compensate the exposures as follows:

Number of Exposures	1	2	3	4	6	8
Exposure Adjustment	0	-1	-1 1/2	-2	-2 1/2	-3

- The above corrections are intended as a general guideline. Some testing may be necessary to produce the desired results.
- Exposure can be compensated in 1/2 or 1/3 EV increments using the exposure compensation function (p.51).



FLASH

FLASH — Four Segment Flash Metering

Four segment flash metering uses data from the focus sensors to control the output of the built-in and/or attached accessory flashes.



Conventional Flash



4-Segment Flash Metering

All four segments are used to meter the flash, but weighting is heaviest on the segment containing the active focus sensor. Weighting varies with subject magnification and the distance between the subject and the background.

The TTL flash metering system determines the flash exposure of the area inside the selected focus area after the shutter has been released.

- Average flash metering is set instead of 4-segment flash metering when the self-timer or rear-flash sync are selected or when the depth-of-field preview button is held when the shutter is released.

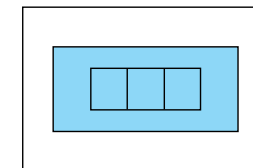

FLASH

Maxxum/Program Flash 5400HS Note

When used with the 5400HS, a preflash is fired before the main exposure. The preflash is metered (14 segment) and fed back to the flash exposure system to more accurately determine the flash exposure.

- The 5400HS will not fire a preflash if **HSS** does not appear in the flash data panel or when rear flash sync, wireless flash, or the 2 second self timer are selected.
- Flash and color meters cannot meter the flash when the high-speed sync indicator appears in the flash data panel.

Custom Function Notes

cusf 20

Select setting 2 to meter all segments evenly. Switch to setting 3 to spot meter your flash exposures (p.102).

FLASH – Slow Sync



Slow-shutter Sync

In P and A-modes, slow-shutter sync sets a slower shutter speed to increase the background or ambient exposure in a flash picture. Flash output is automatically decreased to maintain correct subject exposure.



Conventional Flash

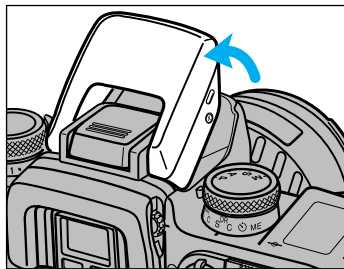

1. Raise the built-in flash or turn the accessory flash on.

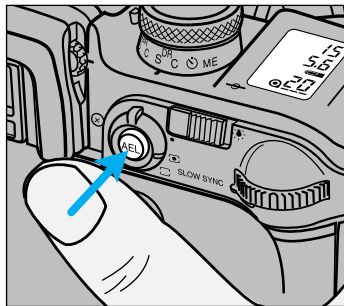

2. While pressing the AE-lock button, press the shutter-release button all the way down to take the picture.
 - AEL and the locked exposure will be displayed in the viewfinder.
 - The shutter speed may not be reduced if the background is bright or a large aperture is set (A-mode).
 - Use a tripod if the shutter speed becomes too slow to allow sharp, hand-held pictures.

Custom Function Notes

cust 10

Setting 2 lets you press the AE-lock button once to activate automatic exposure lock. Press again to cancel (p.96).

FLASH – Rear-Flash Sync



Rear Flash Sync

Slow sync flash exposures can appear unnatural because the motion blur precedes the subject in the final image. Use rear-flash sync to create more natural looking slow shutter speed flash exposures that leave a blur of motion behind the subject.



Conventional Flash

Rear-flash sync can be used with the built-in flash and accessory flashes attached to the accessory shoe or PC terminal.

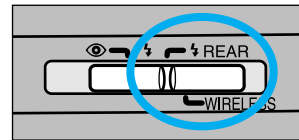

1. Slide the flash-mode switch to REAR.

2. Raise the built-in flash or turn the accessory flash on.

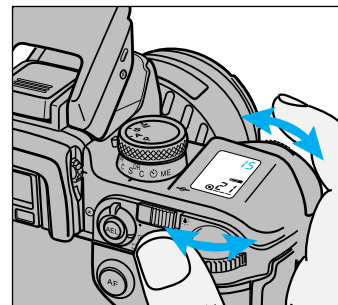

3. Set the shutter speed to 1/60 or slower.

- Flash synchronization returns to front sync (standard operation) when shutter speeds faster than 1/60 are selected.
- Refer to S-mode Flash (p.40) or M-mode Flash (p.43) to select the shutter speed.

FLASH — High Speed Sync



High-speed Sync

The maximum sync speed for this camera is 1/300. However, with the 5400HS accessory flash (sold separately) shutter speeds up to 1/12000 can be used. High-speed sync (HSS) allows faster shutter speeds when fill flash is used on moving subjects outdoors.

HSS also lets you use large aperture/high shutter-speed combinations to separate your subject from the background by limiting the depth-of-field.



Conventional Fill Flash

Attach the 5400HS flash and set it to standard mode.

- **H** automatically appears in the viewfinder at shutter speeds faster than 1/300 sec when the 5400HS is attached.
- Selecting HSS flash mode under fluorescent lighting may result in incorrect exposure.
- Flash and color meters cannot meter the flash when high-speed sync is selected.
- Pressing the depth-of-field button in HSS flash mode prevents release of the shutter.
- HSS is not available in wireless/remote flash mode or when the 2 second self-timer has been selected.

Refer to the 5400HS instruction manual for details.

FLASH — Flash Compensation

Use flash compensation to increase or decrease the output of the built-in or an attached accessory flash up to ± 3 EV in 1/2EV increments.

Flash compensation changes the flash exposure by the amount set relative to the ambient exposure.

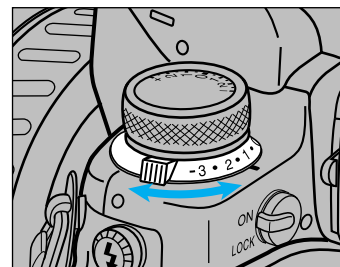

Rotate the flash-compensation dial to the desired compensation value.

- Flash compensation does not modify the output of a flash connected to the PC terminal.
- Flash compensation has no effect on the ambient light exposure.

Flash compensation and exposure compensation can be used together.

FLASH – Flash Bracketing

Use flash bracketing to expose 3, 5, or 7 frame flash exposure brackets in 0.3, 0.5, 0.7, or 1.0 EV increments. Exposures are bracketed by controlling the flash output.

- A larger bracketing increment is recommended when shooting negative film.

Custom Function Notes

cust 11 Switch to setting 2 to change the bracketing sequence to under exposures, metered exposure, over exposures (p.97).

1. Raise the built-in flash or turn the accessory flash on.
2. Turn the drive-mode lever to single frame (S) or continuous advance (C) bracketing mode.
 - The shutter-release button must be pressed for each exposure in both single and continuous advance bracketing modes.
3. Open the control panel, then press the adjust button.

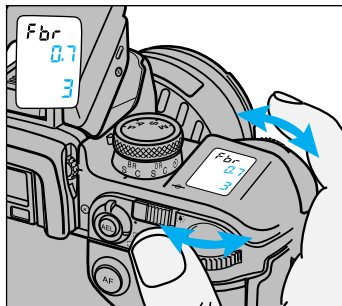
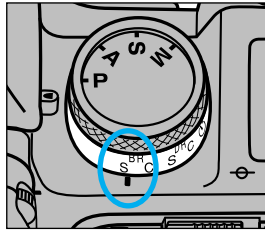

4. Turn the front control dial to set the bracketing increment. (0.3, 0.5, 0.7, or 1.0EV).
5. Turn the rear control dial to set the size of the bracket (3, 5 or 7 frames).



6. Press the shutter-release button partway down to enter the settings.
 - *Fbr 1* appears in the data panel.

7. Compose your subject.

8. When  appears in the viewfinder, press the shutter-release button all-the-way down to take the picture.

- Exposure is locked on the first frame of the series.

9. Repeat steps 7 and 8 until the series is complete.

- The bracket number is indicated in the data panel.
- Turn the main switch to LOCK, change the drive mode, push the built-in flash down, or turn off the accessory flash to cancel the bracketed series.
- Film can be changed in the middle of the bracketed series.

Flash Bracketing with PC Connected Flash Units

1. Set the camera to M-mode (p. 41).

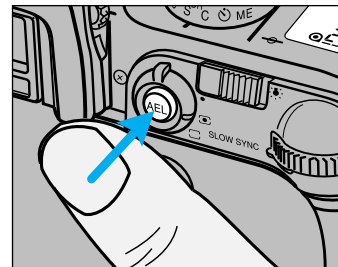

2. Press the AE-lock button while releasing the shutter.

- The exposure will be bracketed by changing the aperture. The output of the flash will not change.

FLASH — Wireless/Remote Off-Camera



Normal Flash

Wireless/Remote Flash is available with the Minolta 5400HS, 5400xi, and 3500xi accessory flashes. Wireless/Remote flash lets you experience the creative control available with an accessory flash.

In Wireless/Remote flash mode, the off-camera flash is triggered by a coded signal from the camera's built-in flash when you press the shutter-release button. When proper exposure has been received, another signal cuts the accessory flash off.



Wireless/Remote Flash

You can also achieve a 2:1 lighting ratio automatically. When remote ratio flash is selected, the off-camera flash provides 2/3 of the full exposure while the built-in flash provides the remaining 1/3.

- Flash and color meters can not be used to meter wireless/remote off-camera flash.
- The shutter speed will be set to 1/60 sec or slower (1/30 sec when remote ratio flash is set).



Wireless/Remote Ratio Flash

Setting Wireless/Remote Flash Mode

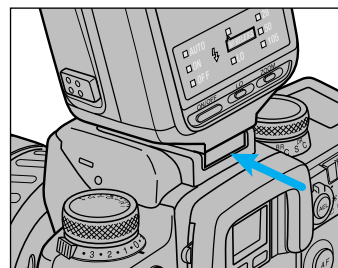

1. Attach the accessory flash to the camera, then turn the camera and the flash on.

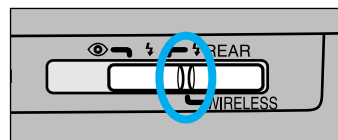

2. Slide the flash-mode switch to **WIRELESS**.

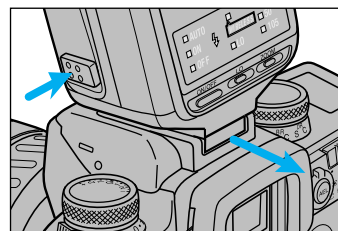

3. Detach the accessory flash, then raise the built-in flash.

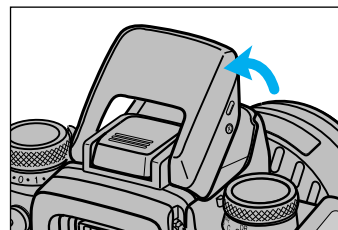

FLASH

FLASH — Wireless/Remote Off-Camera

Taking Pictures in Wireless/Remote Flash Mode

The off-camera flash will provide all of the exposure.

1. Position your camera and 3500xi flash unit using the information on this page.

- If you are not using the 3500xi flash, refer to your flash instruction manual for the correct camera to subject and flash to subject distances.

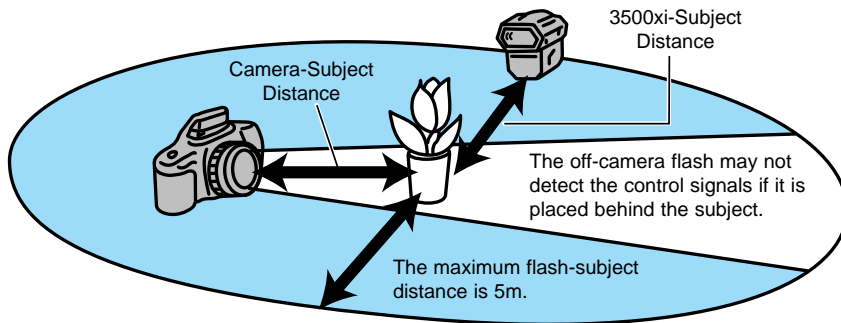

Aperture	Camera – Subject Distance	3500xi – Subject Distance
f/2.8	1.4 - 5.0m (4.6 - 16.0 ft.)	1.0 - 5.0m (3.3 - 16.0 ft.)
f/4	1.0 - 5.0m (3.3 - 16.0 ft.)	0.7 - 4.5m (2.3 - 14.5 ft.)
f/5.6	1.0 - 5.0m (3.3 - 16.0 ft.)	0.5 - 3.2m (1.7 - 10.5 ft.)

- Calculated for ISO 100 film only.

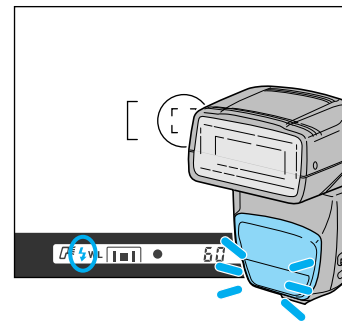

2. Wait until both flash units are fully charged.

- A lightning bolt icon appears in the viewfinder when the built-in flash is charged.
- When the off-camera flash is charged, its AF illuminator will blink.

Press the AE-lock button to test fire the accessory flash.

3. Press the shutter-release button all the way down to take the picture.

Wireless/Remote Ratio Flash

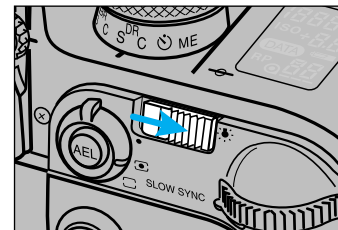

Press the data-panel illuminator when taking the picture.

Both flashes will fire when the shutter is release at a 2:1 ratio.

- The built-in flash will provide 1/3 and the accessory flash will provide 2/3 of the total exposure.

CAUTION

Test firing the flash will activate slow-shutter sync (p. 64) if Cust 10 setting 2 is selected.

- Custom 10 setting 1 is recommended.

FLASH

FLASH — Wireless/Remote Off-Camera

Canceling Wireless/Remote Flash Mode

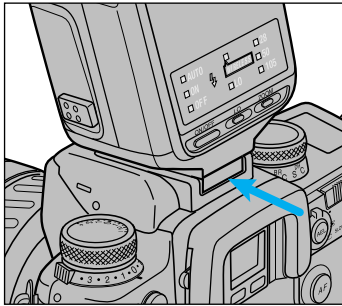

1. Attach the accessory flash to the camera, then turn the camera and flash on.

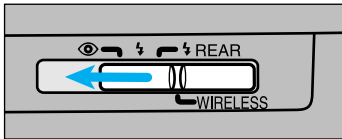

2. Select another flash mode.

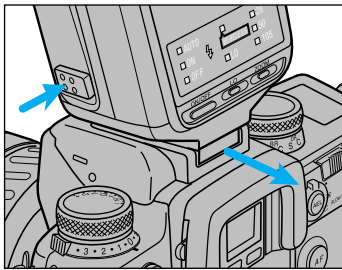

3. Detach the accessory flash.

ADDITIONAL FEATURES

ADDITIONAL FEATURES

OTHER — Eye-Start

Eye-start automatically activates the camera's focus and exposure systems as you bring the camera to your eye.

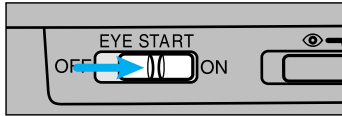

1. Slide the eye-start switch to ON.

2. Turn the main switch to ON.

- The grip sensor and data panel are activated.

...Touching the grip sensor activates the eyepiece sensor.

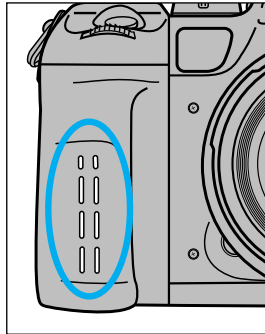

Grip Sensor

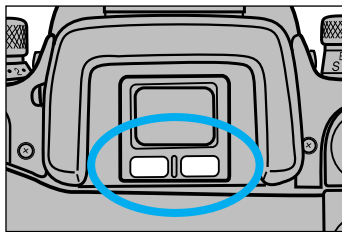

Eyepiece Sensor

When an object is detected near the viewfinder, the camera's systems are activated to set the focus and exposure as you frame your subject.

- Autofocus and exposure systems shut down approx. five seconds after eye or grip sensor contact is broken.
- Infrared absorbing sunglasses or gloves may affect eye-start operation.

Custom Function Notes

cust 7 Switch to setting 2 to activate the eyepiece sensor when the main switch is in the ON position (p.95).

OTHER — Depth-of-Field Preview

Use the depth-of-field preview button to verify how much of your scene will be in focus at the currently selected aperture.

Depth-of-Field — The area in front of and behind the point of focus that appears sharp in the final image.

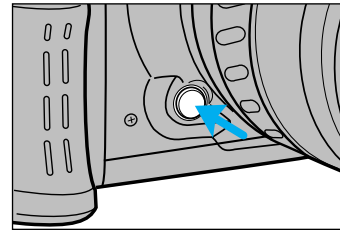

Press the depth-of-field preview button.

- The lens will stop down to the currently selected aperture.

The viewfinder will appear darker at larger f/#s (smaller lens opening).

OTHER — Taking Time Exposures (bulb)



Set the shutter speed to bulb when you want to take time exposures. When selected, the shutter remains open as long as the shutter-release button is held down.

1. Mount the camera on a tripod.

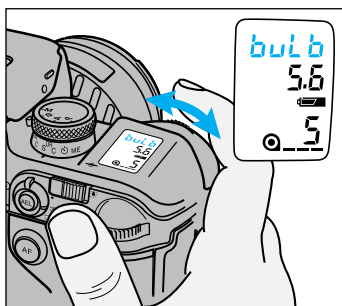

2. Set the camera to M-mode, then turn the front control dial until *bulb* appears in the data panel.

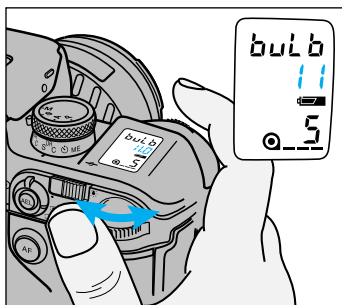

3. Turn the rear control dial to select the aperture.

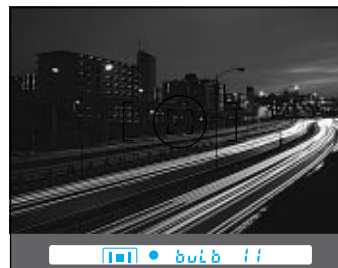

4. Compose the scene and focus on your subject.

If the scene is too dark for autofocus to operate, slide the focus-mode switch to M and focus the lens manually (p. 33).

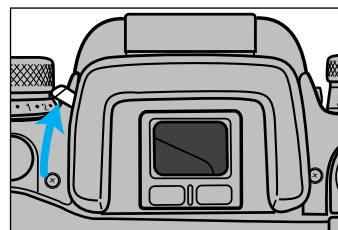

5. Close the eyepiece shutter.

- The eyepiece shutter prevents light from entering through the viewfinder and affecting the metered exposure.

6. Press and hold the shutter-release button to take the picture.

- The shutter remains open as long as the shutter-release button is held down.

Attach a remote cord (p. 80) to reduce image blur.

OTHER — Remote Release Terminal

Attach either the Remote Cord RC-1000S or RC-1000L (sold separately) to reduce blur when taking long exposures.

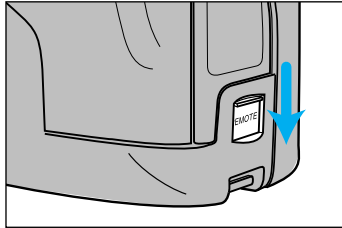

1. Slide the remote-control-terminal cover down.

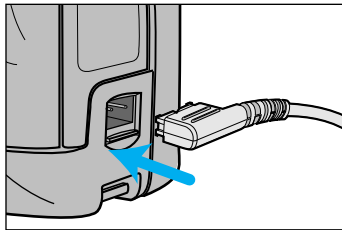

2. Insert the plug into the terminal.

OTHER — PC Terminal

Flash units which can not be connected to the accessory shoe can be connected to the camera via the PC terminal.

- TTL automatic flash metering does not function when the flash is connected to the PC terminal.

1. Set the exposure mode dial to M, then set the shutter speed to 1/300 or slower.

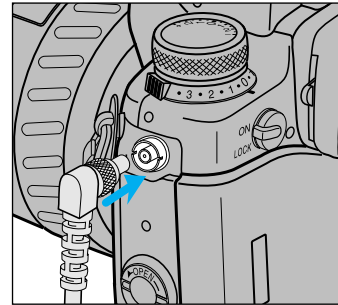

2. Plug the PC connector into the camera's PC socket.

- The flash unit may fire unexpectedly if it is on when the sync. cord is plugged into the PC terminal.
- The PC terminal is compatible with both center positive (normal polarity) and center negative (positive polarity) flash units.

Flash units with a low trigger voltage may not work on this camera. Contact a Minolta Service Facility if your flash has a low trigger voltage.

OTHER — Data Panel Illuminator

Use the data panel illuminator to light up the information in the data panel in low-light situations.

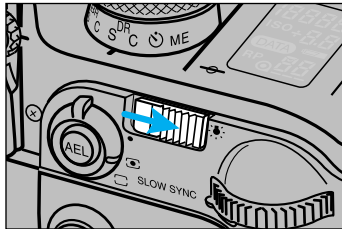

Slide the data panel illuminator switch as shown.

The data panel illuminator shuts off approx. five seconds after the last camera operation.

Custom Function Notes

- Select setting 2 to extend the display duration to 10 seconds.
- [CUSTOM 13]** Switch to setting 3 to extend the display duration to 30 seconds (p.98).

SPECIAL FUNCTIONS

DATA MEMORY

When selected, Data Memory stores the following exposure information for each frame on up to seven 36-exposure rolls.

Shutter Speed
Aperture
Focal Length
Exposure Compensation Value (Bracketing Increment included)
Exposure Mode
Flash Compensation Value (Bracketing Increment included)
Metering Mode

Data is stored in seven separate film areas. Area 1 stores the data from the first roll, area 2 the second, etc. When all the data areas are full, new data is written to area 1, erasing the previous data.

- Data area assignments are not user selectable.
- Only the data for the first exposure of a multiple exposure is stored.
- Data is not stored unless film is loaded.

Selecting Data Memory

1. Open the control panel door, then press the data-memory button.

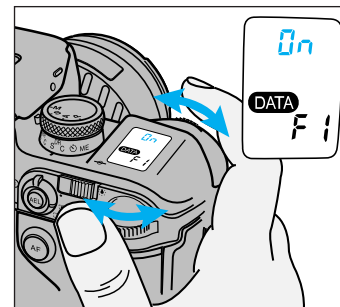
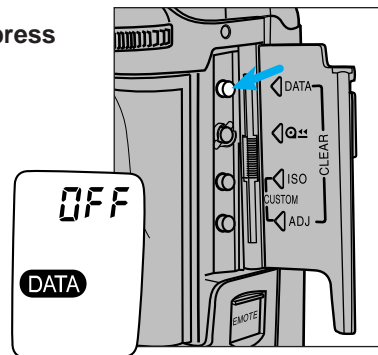

2. Turn either control dial until **Fn** appears in the data panel.

- The film area to which the data will be stored is displayed in the frame counter.

3. Press the shutter-release button partway down to enter the selection.

- **DATA** appears in the data panel when data-memory is on.

Press the data-memory button to display the current film area.

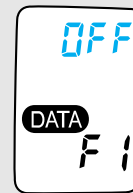

Select **OFF** at step 2 to turn data-memory off.

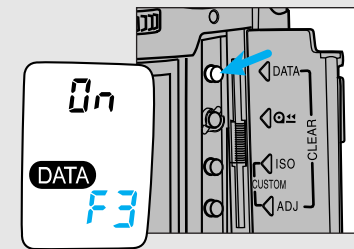

DATA MEMORY

Overwriting

r-rEr appears in the data panel before the data for the first exposure in Area 1 is overwritten.

- *r-rEr* disappears after the first exposure.
- Old data is erased one frame ahead of the current frame.



Area appears only when the film area changes from 7 to 1 and disappears after the data from the first exposure is recorded.

Recalling Data

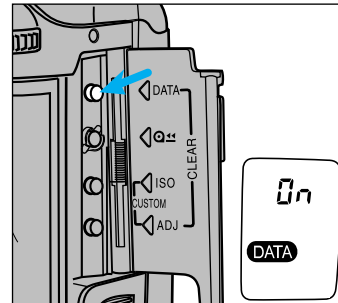

1. Open the control panel door, then press the data-memory button.

- **DATA** and the current data memory mode appear in the data panel.

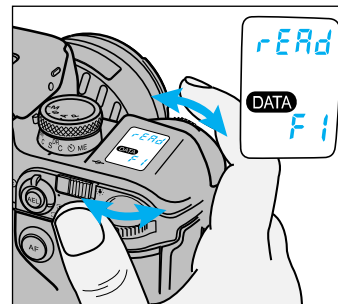

2. Turn either control dial until *r-rEr* and the desired data area appears in the data panel.

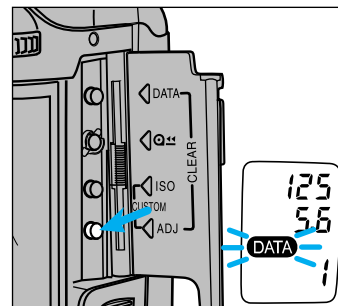

3. Press the adjust button to view the first data area.

- **DATA** blinks in the data panel.

DATA MEMORY

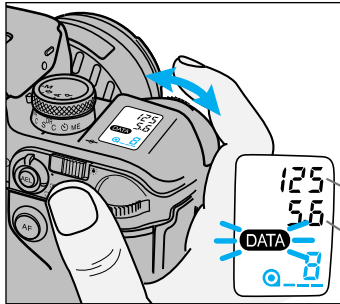

4. Turn the front control dial to select the desired frame number.

- The shutter speed and aperture for the selected frame are displayed in the data panel.

Shutter Speed Display

Aperture Display

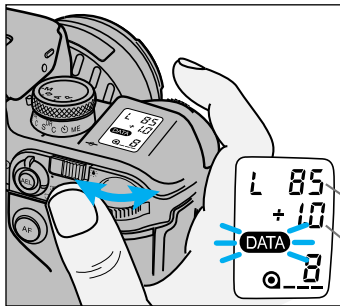

5. Turn the rear control dial one click to display the focal length and exposure compensation / bracketing increment for the selected frame.

- The exposure compensation and bracketing increment are combined into a single value.

Focal Length Display

Exposure Compensation / Bracketing Increment Display

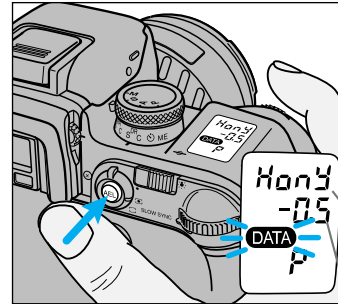

6. Press the AE-lock button at step 4 or 5 to display the metering mode, flash compensation / flash bracketing increment and exposure mode.

- The flash compensation and bracketing increment are combined into a single value.

Metering Mode Display

HonY - 14-Segment Honeycomb Pattern (p.45)

RuE - Center Weighted Average (p.47)

SPot - Spot (p. 46)

Flash Compensation / Bracketing Increment Display

0.0 - Flash fired without compensation.

- - - Flash didn't fire.

7. Press the adjust button again to return to data memory *rERd*.

8. Turn either control dial to select data memory *On* or *OFF*, then press the shutter-release button partway down to enter the selection.

- Press the shutter-release button partway down twice to return to standard operation mode with data memory on.

DATA MEMORY

Deleting Stored Data

The data in all of the film areas will be deleted. Film areas cannot be cleared individually.

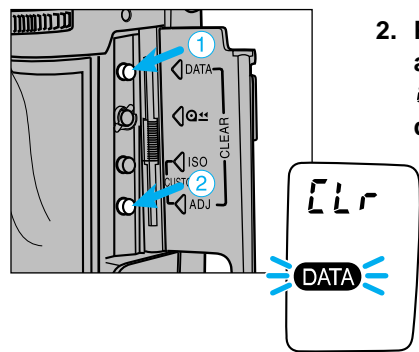

1. Open the control panel door.
2. Press the data-memory ① and adjust ② buttons until **CLR** appears and **DATA** blinks in the data panel.

3. Press the data-memory button again.
 - **CLR** blinks while the data is being deleted.
 - The data panel returns to the standard display after the data in the film areas has been cleared.

*Do not operate the camera while **CLR** blinks in the data panel.*

CUSTOM FUNCTIONS

Use the custom functions to tailor the camera to your shooting style or preferences. The customizable functions are explained on pages 92-102.



1. Open the control panel door.
2. Press the ISO button ①, then the adjust button ②.

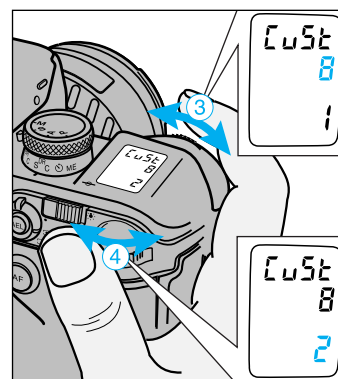

3. Turn the front control dial to select the custom function number.
4. Turn the rear control dial to select the desired setting.
5. Press the shutter-release button partway down to enter the settings.

To reset the custom functions to their default setting (1)...

1. Turn the main switch to **LOCK**.
2. Open the control panel door.
3. Press the adjust button and turn the main switch to **ON**.
 - **CLR** will blink in the data panel when the custom functions are returned to their default settings.

CUSTOM FUNCTIONS

Cust 1 — AF/Release priority

1 – AF priority

Shutter will not release until ● or (●) appears in the viewfinder.

2 – Release Priority

Shutter releases even if the focus cannot be confirmed. Use release priority when photographing moving subjects.

- RP will appear in the data panel.



Cust 2 — Film Rewind Start

1 – Automatic

Film is automatically rewound at the end of the roll.

2 – Manual

User must press the manual-rewind button to initiate rewind (p. 24).

Cust 3 — Film Tip

1 – Film is completely rewound into the cartridge.

2 – Leader is left out of the cartridge after rewind.

3 – Leader left out after rewind. / Camera setup for Mid Reload.

Mid Reload

Mid Reload decreases the chances of accidental double exposure when reloading a partially exposed roll of film.

- Reloading a partially exposed roll increases the risk of film damage (scratches) caused by dust and grit.

1. Set custom function 3 to setting 3 .

2. Load the film (p. 15).

- The film is automatically advanced to frame 1.

3. Open the control panel door, then press and hold the adjust button until 1 blinks in the data panel.

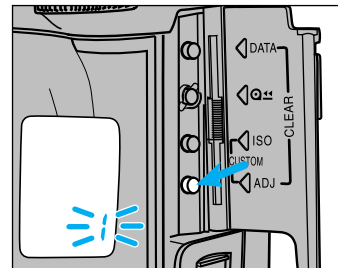

4. Turn either control dial until the frame number you want to advance the film to blinks in the data panel.

- Advance the film a minimum of two frames past the last exposed frame.

5. Press the adjust button.

- The film is automatically advanced to the desired frame.

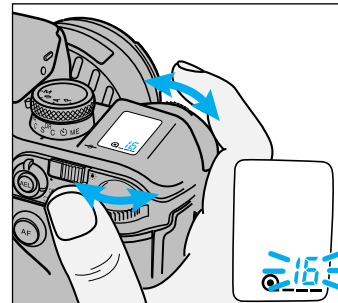

CUSTOM FUNCTIONS

Cust 4 — DX Memory

1 – DX Memory Off

Film speed is always set to the DX-coded ISO. Non-DX-coded film is set to the previous roll's ISO.

2 – DX Memory On

Changes to the film speed for a DX coded roll are saved and applied to future rolls with the same DX coded ISO. Use to consistently over/under-expose a specific film type.

- Film must be loaded before the ISO can be changed.

Cust 5 — Release Lock (Film)

1 – Release Lock Off

2 – Release Lock On

Shutter cannot be released unless film is loaded or the back cover is open.

-  blinks in the frame counter if the shutter-release button is pressed when film is not loaded.

Cust 6 — Focus Hold Button (Lens)

The mounted lens must have a focus hold button.

1 – Focus Hold

Pressing the focus-hold button on the lens locks the focus.

2 – Spot Focus

Pressing the focus-hold button on the lens selects the center focus sensor (p.31).

3 – Continuous Focus

Select this setting when focusing on moving subjects.

Pressing the focus-hold button on the lens selects continuous focus.

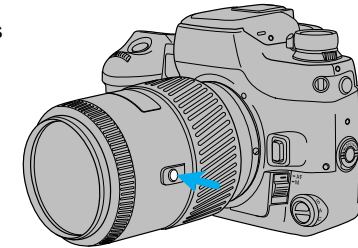

Cust 7 — Eyepiece Sensor

1 – Grip sensor activated

Eyepiece sensor is activated when the grip sensor is tripped.

2 – Main switch activated

Eyepiece sensor is activated when the main switch is in the ON position. Use this setting when the grip sensor is not being tripped (user wearing gloves).

- Slide the main switch to LOCK when the camera is not being used.

CUSTOM FUNCTIONS

Cust 8 — Frame Counter

- 1 – Frame counter in data panel counts up.
- 2 – Frame counter in data panel counts down.
 - The frame counter counts up when non-DX coded film is loaded.

Cust 9 — AF Button

1 – Selectable focus area

Press the AF button and turn the control dial to specify the desired local focus area. See page 31 for details.

2 – Spot Focus

Press the AF button to focus using the center focus sensor (p. 31).

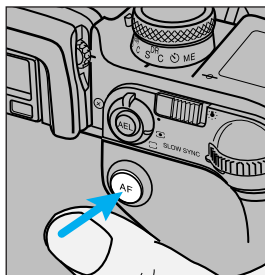

Cust 10 — AE-Lock Button

- AEL appears in the viewfinder when AE-lock button is active (down).
- Slow sync is selected when the built-in flash is up or an attached accessory flash is on.
- Manual shift is selected when the exposure mode is set to manual.

- 1 – Press to activate, release to cancel.
- 2 – Press once to activate, press again to cancel.
 - Turning the built-in flash on or off cancels AE lock.

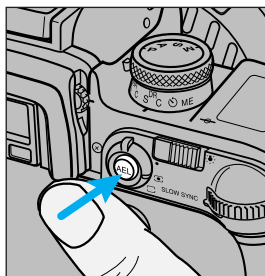

Cust 11 — Bracketing Sequence

1 – Metered exposure, Underexposure(s), Over-exposure(s)

- A 5 frame bracket in 1/2EV increments is exposed in the following order...
Normal → -0.5EV → +0.5EV → -1.0EV → +1.0EV

2 – Underexposure(S), Metered exposure, Over-exposure(s)

- A 5 frame bracket in 1/2EV increments is exposed in the following order...
-1.0EV → -0.5EV → Normal → +0.5EV → +1.0EV

Cust 12 — Rewind Speed

1 – Fast Rewind

Rewinds a 36 exposure roll in approximately 6 seconds.

2 - Slow (silent) Rewind

Rewinds a 36 exposure roll in approximately 9 seconds.

CUSTOM FUNCTIONS

Cust 13 — Meter/Data Panel Illuminator Display Duration

- Selecting longer display durations reduces battery performance.

1 – 5 sec

2 – 10 sec

3 – 30 sec

Cust 14 — AF Area Display

- Press and hold the AF button to display the focus area LEDs.
- Pressing the lens focus hold button does not display the focus area LEDs.

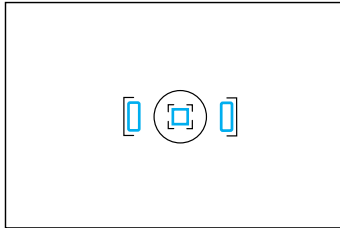

1 - Focus Area LEDs display the active focus area for 0.1 sec after the focus locks.

2 - Focus Area LEDs display the active focus area for 0.4 sec after the focus locks.

3 - Local focus areas display only when the AF button is pressed.

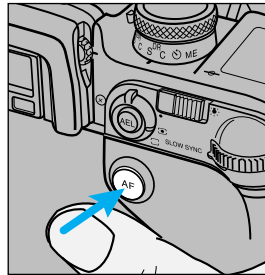

Cust 15 — Eyestart Switch

Dial-lock - Disengages the control dials to prevent an accidental turn of the control dials from changing the exposure settings.

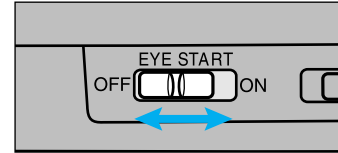

1 - Turns Eyestart on and off (p. 76).

2 - Turns Dial-lock on and off. Eyestart is always on.

3 - Turns Dial-lock on and off. Eyestart is always off.

Cust 16 — Release Lock (Lens)

1 - Shutter cannot be released if a lens is not attached.

- -- appears (blinks) in the data panel when the shutter-release button is pressed.

2 - Shutter can be released if a lens is not attached.

Use when mounting the lens to a non-coupling lens mount (telescope, microscope etc.).

Cust 17 — AF Drive Speed

1 - Speed priority

2 - Silent drive

CUSTOM FUNCTIONS

Cust 18 — Control Dial Tasking

1 – Default operation

Exposure Mode	Control Dial Tasking	
	Front Control Dial	Rear Control Dial
P – Mode	no function	no function
A – Mode	aperture	aperture
S – Mode	shutter speed	shutter speed

2 – Creative Program

Creative program control (PA / Ps) lets you override the exposure settings selected by the camera in P- mode. A and S – mode operation does not change.

Exposure Mode	Control Dial Tasking	
	Front Control Dial	Rear Control Dial
P – Mode	Ps - shutter speed	PA - aperture
A – Mode	aperture	aperture
S – Mode	shutter speed	shutter speed

3 – Exposure Compensation

Changes the tasking for the rear control dial to exposure compensation. Tasking for the front control dial is the same as setting 1.

- The exposure compensation value is displayed in the meter index.
- Exposure compensation dial must be set to +/- 0.
- Compensation range is +/- 3 EV for both 1/2 and 1/3 EV increments.
- Lower viewfinder indicators will disappear when the rear control dial is operated.

Exposure Mode	Control Dial Tasking	
	Front Control Dial	Rear Control Dial
P – Mode	no function	exposure
A – Mode	aperture	compensation
S – Mode	shutter speed	

Cust 18-2 Creative Program PA/Ps Mode Operation

After the AE system has been activated, you can change the shutter speed or aperture selected by the camera. Creative program remains active until the data panel display disappears.

Custom Function Notes

CUST 13 Refer to page 98 to change the data panel display duration.

While the aperture/shutter speed are displayed in P-mode...

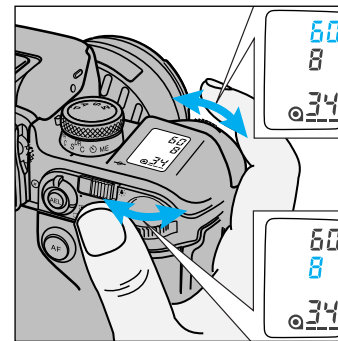

Turn the front control dial to change the shutter speed.

- Aperture is adjusted automatically.

Turn the rear control dial to change the aperture.

- Shutter speed is adjusted automatically.

- The aperture and shutter speed change in 1/2 or 1/3 EV increments depending on the position of the exposure compensation dial.
- Flash can not be used with the PA and PS modes.
 - Built-in and accessory flashes will not fire when the PA and PS modes are active.
 - PA and Ps modes can not be selected when **CFE** appears in the viewfinder.
- If the shutter speed or aperture blink, the required setting is not available. Turn the control dial until the blinking stops.

Cancelling PA / Ps Mode

Wait until the displayed data disappears for the data panel or raise the built-in flash.

CUSTOM FUNCTIONS

Cust 19 — Control Dial - Exchanged Control

1 – Unchanged from Cust 18.

2 – Front and rear control dial functions exchanged.

- Control dial tasking does not change for bracketing, data memory, and custom functions.

Cust 20 — Flash Metering

1 – 4-Segment Flash Metering (p. 63)

2 – Average metering

All flash metering segments are weighted evenly.

3 – Spot Metering

Flash is metered by the segment corresponding to the currently selected Local Focus Area.

- Do not recompose the image after locking focus. Flash exposure is TTL metered by the segment used to lock focus.

Cust 21 — Exposure Compensation Display

1 – No display

Exposure compensation value is not displayed in the data panel.

2 – Display

Exposure compensation value is displayed in the data panel when the dial is operated.

- Lower viewfinder indicators will disappear when the dial is operated.



APPENDIX

ACCESSORY INFORMATION

Data Memory Back DM-9

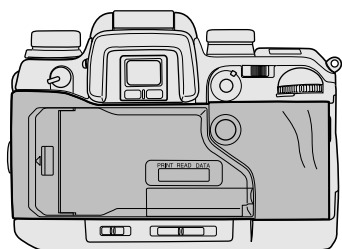

Designed specifically for the Maxxum/Dynax 9, the Data Memory Back DM-9 can store exposure data for up to 400 rolls of 36 exposure film on a 2MB SmartMedia card. The saved data can be displayed in the data panel or on your home computer.

The Data Memory Back DM-9 can also imprint aperture/shutter speed data, frame count, film ID, the date, or the time of exposure in between frames.

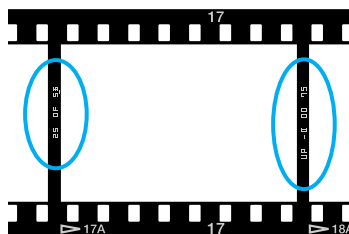

Vertical Control Grip VC-9

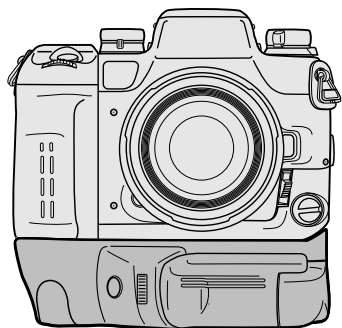

Another Maxxum/Dynax 9 exclusive, the Vertical Control Grip VC-9 has duplicated basic control surfaces (shutter-release button, control dials, grip switch, etc.) for improved vertical operation.

Multiple power source capability has also been incorporated to extend the length of shooting sessions in between battery changes.

Quartz Data Back QD-9

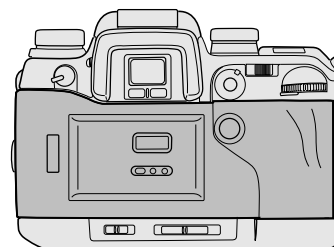

Use the Quartz Data Back QD-9 to record the time or date in the lower right-hand corner of each frame.

Focusing Screen 9

Four new focusing screens have been introduced for exclusive use with the Maxxum/Dynax 9. The G (standard), L, and S screens use Minolta's new spherical acute matte surface, designed to produce less image shading in the center of the focusing screen.

Designed for users of large aperture lenses, The M type screen uses the super spherical acute matte surface for greater light dispersion and sharper focus control.

- The edges of the viewfinder may appear dark when some telephoto lenses are used with the type G, S, and L focusing screens. The final image will not be affected.

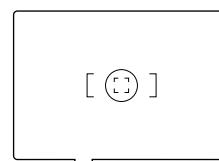

Type G

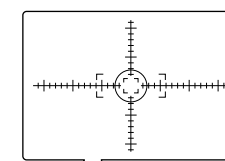

Type S

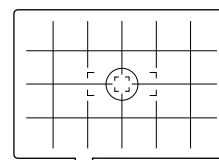

Type L

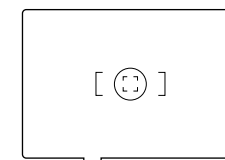

Type M

ACCESSORY INFORMATION

This camera is designed to work specifically with lenses and accessories manufactured and distributed by Minolta. Using incompatible accessories with this camera may result in unsatisfactory performance or damage the camera and accessories.

Compatibility of Accessories

Lenses

- All Minolta AF lenses can be used with this camera.
- MD and MC series lenses (manual focus) cannot be used with this camera.

Flashes

- All Minolta i, si, and HS series flash units, and the Vectis SF-1 flash, are compatible with this camera. The flash will always fire when the flash unit is on.
- The Flash Shoe Adapter FS-1100 is required to mount AF series flash units (4000AF, 2800AF, 1800AF, and Macro flash 1200AF).
- The AF illuminator will not activate when the FS-1100 is attached.
- X-series flashes cannot be used with this camera.

Others

- The following accessories are not compatible with this camera:
Control Grip CG-1000 Data Receiver DR-1000
- Remove the eyepiece cup when attaching a finder accessory (AngleFinder, etc.).

The information in this manual is relevant for products introduced before January 1999. Contact the nearest authorized Minolta Service Facility to obtain information for products released after this date.

EXPOSURE WARNINGS

Indicators will blink in the viewfinder or data panel when there is a problem with the exposure.

MODE	DISPLAY	CAUSE	ACTION
P A S M		Scene or subject brightness is beyond the camera's metering range.	Bright Light Use slower speed film, a neutral density (ND) filter, or reduce the light level of your surroundings.
P		Light level is beyond the range of available shutter speeds and apertures.	Low Light Use higher speed film or a flash.
A		The required shutter speed is beyond the range of the camera.	Select a larger or smaller aperture until the display stops blinking.
S		The required aperture is beyond the range of the lens.	Select a faster or slower shutter speed until the display stops blinking.

TROUBLE SHOOTING

PROBLEM	CAUSE
No display appears when the camera is switched on.	Batteries are loaded incorrectly.
	Batteries are exhausted.
Autofocus does not work when shutter-release button is pressed partway down.	Situation is unsuitable for autofocus.
	Camera is set to manual focus mode.
	Subject is too close.
Shutter cannot be released.	Focus cannot be confirmed.
	Camera is attached to a microscope or telescope.
	Custom Function 5 set to setting 2.
Flash picture is too dark.	Subject is beyond flash range.
Lower part of flash picture is dark.	Lens hood attached.
Err appears in the data panel.	Camera Malfunction

SOLUTION	PAGE
Remove and reinstall the batteries.	10
If the camera battery is exhausted, install a new battery.	10
Use focus hold or manual focus.	21/33
Slide the focus-mode switch to AF.	18
Check the minimum focus distance for your lens.	-
Use focus hold or manual focus.	21/33
Set Custom Function 16 to setting 2.	99
Set Custom Function 5 to setting 1.	94
Make sure the subject is within the flash range.	23
Remove lens hood. The distance between the subject and the camera must be at least 1m (3.3ft.) when the built-in flash is used.	-
Remove and reinstall the batteries. If normal camera operation does not resume or the camera malfunctions repeatedly, contact an authorized Minolta Service Facility.	10

- Contact your nearest Minolta Service Facility if the problem you are experiencing is not covered or the condition continues.

CARE AND STORAGE

Operating Temperature and Conditions

- This camera is designed for use from -20 to 50 °C (4 to 122 °F).
- Never leave your camera where it may be subjected to extreme temperatures such as the glove compartment of a car.
- Data panel response time will be slow at colder temperatures. The display will temporarily darken at higher temperatures, but will restore when the temperature normalizes.
- This camera is not waterproof or splashproof.
- Never subject the camera to extreme humidity.
- To prevent condensation from forming, place the camera in a sealed plastic bag when bringing it from cold environment to a warm environment. Allow it to come to room temperature before removing it from the bag.
- The low-battery symbol may appear even with fresh batteries depending on the storage conditions. To restore camera power, repeat turning the camera on and off.
- Battery capacity decreases at colder temperatures. Keep your camera and spare batteries in a warm inside pocket when shooting in cold weather. Batteries will regain some of their capacity when warmed to normal operating temperature.
- Tape over the exposure-mode and exposure-compensation dials if the film needs to be removed from the camera in a darkroom or changing bag due to a drive problem. Fogging may occur if the luminous dials are not covered.

Storage

When storing your camera for extended periods,

- Always attach the protective caps.
- Store in a cool, dry, and well-ventilated area away from dust and chemicals such as moth balls. For long periods, place the camera in an airtight container with a silica gel drying agent.
- Periodically release the camera's shutter to keep it operating properly.
- Before using after prolonged storage, check the camera's operation to make sure it is functioning properly.

Cleaning

- If the camera or lens barrel is dirty, wipe it gently with a soft, clean, dry cloth.
If the camera or lens comes in contact with sand, gently blow away loose particles - wiping may scratch the surface.
- To clean the lens surface, first brush away any dust or sand then, if necessary, moisten a lens tissue with lens cleaning fluid and gently wipe the lens in a circular motion, starting from the center.
- Never place lens fluid directly on the lens.
- Never touch the interior of the camera, especially the shutter and mirror, doing so may impair their alignment and movement.
- Dust on the mirror will not affect the exposure but may affect the focus. Use a blower brush to remove dust from or around the mirror.
- Never use compressed air to clean the camera's interior, it may cause damage to sensitive interior parts.
- Never use organic solvents to clean the camera.
- Never touch the lens surface with your fingers.

Before Important Events

- Check the camera's operation carefully, or take test photographs.
- Minolta is not responsible for any loss that may occur due to an equipment malfunction.

Questions and Service

- If you have questions about your camera, contact your local camera dealer or write to the Minolta distributor in your area.
- Before shipping your camera for repair, please contact an authorized Minolta Service Facility for details.

SPECIFICATIONS

Camera Type:	35mm SLR with built-in flash, autoexposure (AE), and omni-dimensional predictive autofocus (AF)
Lens Mount:	Minolta A-type bayonet mount
Viewfinder*:	Eye level, fixed pentaprism, 100% field of view
Magnification*:	0.73X * With a 50mm lens focused at infinity.
Focusing Screen:	Spherical matte, user interchangeable screens available.
Diopter:	-1 diopter, Adjustment: -3 – +1
Shutter	
Type:	Electronically-controlled, vertical-traverse, focal-plane type
Speeds:	30 sec. - 1/12000 sec., bulb
Flash sync speed:	1/300 or slower (synchronizes with all speeds in HSS mode).
Focus	
Type:	TTL phase-detection system, multi metering with cross hair type CCD line sensor metering cell. Autofocus and manual focus modes.
AF Sensitivity Range:	EV -1 to 18 (ISO 100)
AF Illuminator:	Built-in 3 beam LED. Automatically activated in low-light/low-contrast situations. Range: 0.7 - 7m (With a standard 50mm lens.)
AF Control:	Single-shot, continuous, automatic AF-mode selection.
Exposure	
Modes:	P, A, S, M (PA/Ps available as a Custom Function)
Type:	TTL metering; direct TTL metering for flash
Metering Cell:	Ambient: 14-segment honeycomb, center weighted average, spot (5.5 Ø) Flash: 4-segment SPC
Metering Range :	14-segment metering: EV 0-20, (ISO 100, f/1.4 lens) Center weighted average: EV 0-20, Spot metering: EV 3 - 20
Film-speed Setting:	Automatic: ISO 25 to 5000 for DX-coded film. Manual: ISO 6 to 6400 in 1/3 EV increments. Flash: ISO 25 - 1000.

112

Film Transport

Loading:	Auto load
Drive Modes:	Single frame and Continuous advance (2 or 5.5 frames/sec. (4.5 in continuous AF mode)), self-timer (10 or 2 second), exposure bracketing (single frame or continuous advance), and multiple exposure.
Rewind:	Auto rewind, manual start (Count-down display) High speed or Silent.
Frame counter:	Forward (shows number of exposures taken)

Built-in Flash

GN:	12 (ISO 100 in meters)
Coverage:	24mm angle of view
Recycling Time:	Approx. 2.5 sec. (according to Minolta test methods)
Modes:	Fill-flash, Fill-flash with red-eye reduction, Flash Cancel, Wireless flash, Slow-sync, and Rear-flash sync.

Additional

Power:	Two CR123A lithium batteries
Battery Performance:	

Flash Use (%)	24 Exposure Rolls		36 Exposure Rolls	
	20 °C	-20 °C	20 °C	-20 °C
0	45 rolls	40 rolls	30 rolls	28 rolls
50	23 rolls	15 rolls	15 rolls	10 rolls
100	14 rolls	9 rolls	9 rolls	6 rolls

Test Conditions : Lens (24-85 f/3.5-4.5) is focused from infinity to 2m three times and the shutter-release button held partway down for ten seconds before each exposure.

- Battery performance will vary with usage conditions.
- Exposures taken at a rate of 3 rolls/month for 24 exposure rolls, 2 rolls/month for 36 exposure rolls (starting with fresh batteries).

Dimensions (WxHxD):	155.0 x 111.0 x 75.0mm (WxHxD)
Weight :	910g (w/o camera battery)

Specifications are based on the latest information available at the time of printing and are subject to change without notice.

113



Minolta Co., Ltd.	3-13, 2-Chome, Azuchi-Machi, Chuo-Ku, Osaka 541-8556, Japan
Minolta GmbH	Kurt-Fischer-Strasse 50, D-22923 Ahrensburg, Germany
Minolta France S.A.	365 Route de Saint-Germain, F-78420 Carrières-Sur-Seine, France
Minolta (UK) Limited	7 Tanners Drive, Blakelands, Milton Keynes, MK14 5BU, England
Minolta Austria Ges. m.b.H.	Amalienstrasse 59-61, A-1131 Wien, Austria
Minolta Camera Benelux B.V.	Zonnebaan 39, P.O. Box 6000, NL-3600 HA Maarssen, The Netherlands
Belgium Branch	Kontichsesteenweg 38, B-2630 Aartselaar, Belgium
Minolta (Schweiz) AG	Riedstrasse 6, CH-8953 Dietikon, Switzerland
Minolta Svenska AB	Albygatan 114, S-171 54 Solna, Sweden
Finland Branch	Niittykatu 6 PL 37, SF-02201 Espoo, Finland
Minolta Portugal Limitada	Av. do Brasil 33-A, P-1700 Lisboa, Portugal
Minolta Corporation	
Head Office	101 Williams Drive, Ramsey, New Jersey 07446, U.S.A.
Los Angeles Branch	11150 Hope Street Cypress, CA 90630, U.S.A.
Minolta Canada Inc.	
Head Office	369 Britannia Road East, Mississauga, Ontario L4Z 2H5, Canada
Vancouver Branch	230-3771 Jacombs Road, Richmond, B.C. V6V 2L9, Canada
Minolta Hong Kong Limited	Room 208, 2/F, Eastern Center, 1065 King's Road, Quarry Bay, Hong Kong
Minolta Singapore (Pte) Ltd.	10, Teban Gardens Crescent, Singapore 608923
Shanghai Minolta Optical Products Co., Ltd.	368 Minolta Road, Songjiang, Shanghai, China

© 1999 Minolta Co., Ltd. under the Berne Convention and
Universal Copyright Convention

