

Thank you for purchasing the Minolta 3D 1500.
Please take the time to read through this instruction manual so you can enjoy all its features.

For information on installing and operating the included application software, please read the software instruction manual saved in the CD-ROM as a pdf file.
This manual contains information regarding products introduced before Sep., 1999.
To obtain compatibility information for products released after this date, contact a Minolta Service Facility listed on the back cover of this manual.



This mark on your camera certifies that this camera meets the requirements of the EU (European Union) concerning interference causing equipment regulations.
CE stands for Conformité Européenne (European Conformity).

Digital Camera: 3D 1500



Tested To Comply
With FCC Standards

FOR HOME OR OFFICE USE

This device complies with Part 15 of the FCC Rules.
Operation is subject to the following two conditions:
(1) This device may not cause harmful interference,
and (2) this device must accept any interference received, including interference that may cause undesired operation.

Tested by the Minolta Corporation
101 Williams Drive, Ramsey, New Jersey 07446,
U.S.A.

This Class B digital apparatus complies with Canadian ICES-003.
Cet appareil numérique de la classe B est conforme à la norme NMB-003 du Canada.

Do not remove the ferrite cores from the cables.

- MetaFlash™, MetaFlash™ Studio, and MetaStream™ are trademarks of MetaCreations Corporation.
- Windows® is a registered trademark in the United States and other countries of Microsoft Corporation.

FOR PROPER AND SAFE USE

Read and understand all warnings and cautions before using this product.

WARNING

Batteries may become hot or explode due to improper use.

- Use only the batteries specified in this instruction manual.
- Do not install the batteries with the polarity (+/-) reversed.
- Do not subject batteries to fire or high temperatures.
- Do not attempt to recharge, short, or disassemble.
- Do not mix batteries of different types, brands, or ages.

Use caution, accidents may occur when using this product near young children.

Keep batteries or things that could be swallowed away from young children. Contact a doctor immediately if an object is swallowed.

Immediately remove the batteries and discontinue use if...

- the camera is dropped or subjected to an impact in which the interior is exposed.
- the product emits a strange smell, heat, or smoke.

Do not walk while looking at the monitor.

Do not disassemble. Electric shock may occur if a high voltage circuit inside the camera is touched.

Take your camera to a Minolta Service Facility when repairs are required.

CAUTION

The heat of the camera rises with extended periods of use. Use caution when handling the camera or removing the batteries and compact flash card.

The lens retracts when the camera is turned off or Auto Power Off is activated. Touching the lens barrel while it is retracting may cause injury.

BEFORE YOU BEGIN

Check the packing list before you begin. If some parts are missing, contact your camera dealer or a Minolta Service Facility listed on the back cover of this manual.

- **Minolta 3D 1500 camera** (x 1)
- **Camera Bracket CB-3D1** (x 1)
- **AA-size Alkaline Batteries** (x 8)
- **AC Adapter** (x 1)
- **Quest® 8 HOUR NIMH BATTERY CHARGER and NiMH BATTERIES**
 - Quest® AA-size rechargeable NiMH batteries (x 4)
 - Size AA & size AAA NiMH battery charger (x 1)
- **Video Cable VC-EX1** (x 1)
- **CD-ROM** (x 1)
 - MetaFlash™ Studio for Windows®
 - MetaStream™ Viewer Plug-in (Web browser Plug-in)
 - MetaFlash™ Studio User Guide (PDF file)
 - Adobe Acrobat™ Reader 4.0 Installer
- **Floppy Disk** (x 1)
 - Calibration File
 - Script file for reading the number of MetaFlash fired (GETSCNT.CSM)
- **LexarMedia JumpShot® USB connection kit**
 - 32MB USB-enabled CompactFlash card (x 1)
 - JumpShot® USB cable (x 1)
- **Documentation**
 - Camera Instruction Manual (this manual) (x 1)
 - Dimâge EX Camera Instruction Manual (x 1)
 - Dimâge EX Version 2 Guide (x 1)
 - Warranty (x 1)

[IMPORTANT] About the Calibration File

The attached floppy disk contains a calibration file. The data in this file is required to generate 3D images for MetaFlash Studio from the image data which is taken with the 3D 1500 camera. You could generate no 3D image without this data.

The calibration file is unique to each 3D 1500 camera. You can not use it for another 3D 1500 camera. You can not use the calibration file for another 3D 1500 camera with your 3D 1500 camera, either.

Exercise adequate care when handling or storing the floppy disk so that the calibration file on the floppy disk may not be lost or corrupted. Be sure to take a backup copy of the floppy disk in case it is lost or damaged. It is recommended that, whenever possible, the data on the floppy disk be saved on two or more storage media such as another floppy disk, hard disk, and Zip disk.

FOR PROPER AND SAFE USE2

BEFORE YOU BEGIN3

TABLE OF CONTENTS4

NAMES OF PARTS6

MATERIALS COVERED IN THIS MANUAL8

PREPARATION

 INSERTING BATTERIES [Camera Body]10

 INSERTING BATTERIES [MetaFlash].....12

 Low Battery Indicator [Camera Body].....14

 Rules of Thumb for Replacing the Batteries [MetaFlash]14

 Auto Power Off [Camera Body]15

 Auto Power Off [MetaFlash]15

 Using the AC Adapter [Camera Body Only]16

 COMPACT FLASH CARD17

 Inserting the Compact Flash Card.....17

 Removing the Compact Flash Card18

 ATTACHING AND REMOVING THE METAFASH UNIT.....20

 Attaching the MetaFlash Unit to the Camera20

 Removing the MetaFlash Unit from the Camera.....20

 ATTACHING THE CAMERA BRACKET21

BEFORE TAKING PICTURES

 PROCESSES FOR GENERATING A 3D IMAGE.....23

 IMPORTANT PREPARATIONS FOR TAKING PICTURES24

 Subjects That are Not Suited for the 3D 150024

 Making the Background of the Subject Solid Black25

 Brightness of the Subject and Its Surrounding.....26

 To Get Better 3D Images.....27

TAKING PICTURES

 BASIC RECORDING PROCEDURE29

 EXPOSURE COMPENSATION34

 TRANSFERRING IMAGE DATA.....36

FOR YOUR INFORMATION

 WHEN TO REPLACE THE XENON LAMP38

 TROUBLESHOOTING.....39

 ACCESSORIES42

 CARE AND STORAGE44

 TECHNICAL DETAILS.....47

Refer to the Dimâge EX Camera Instruction Manual for more details.

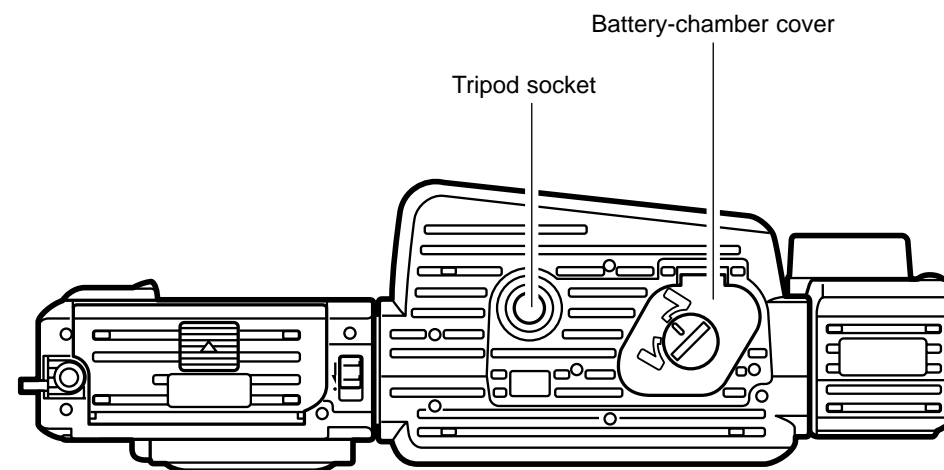
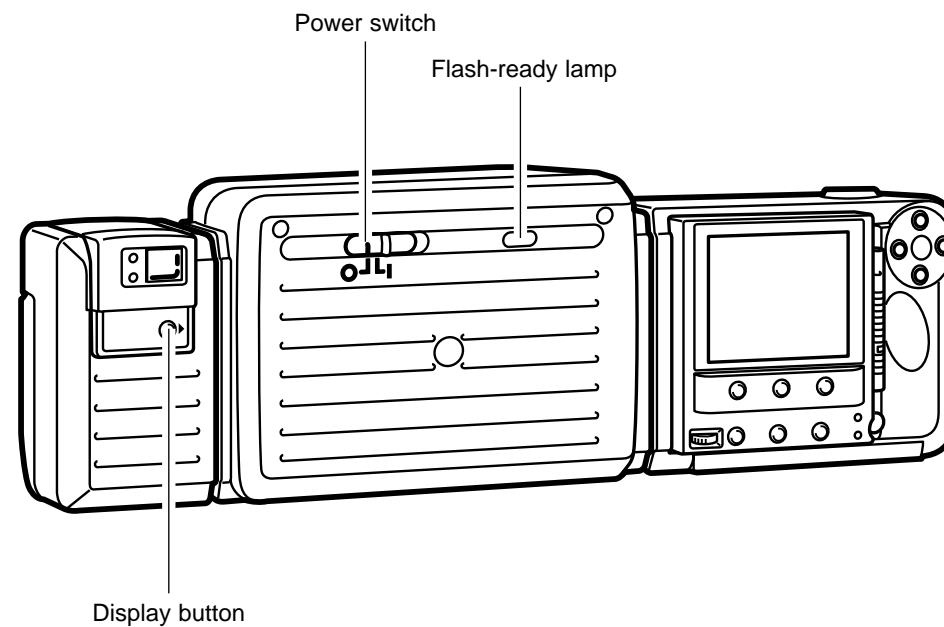
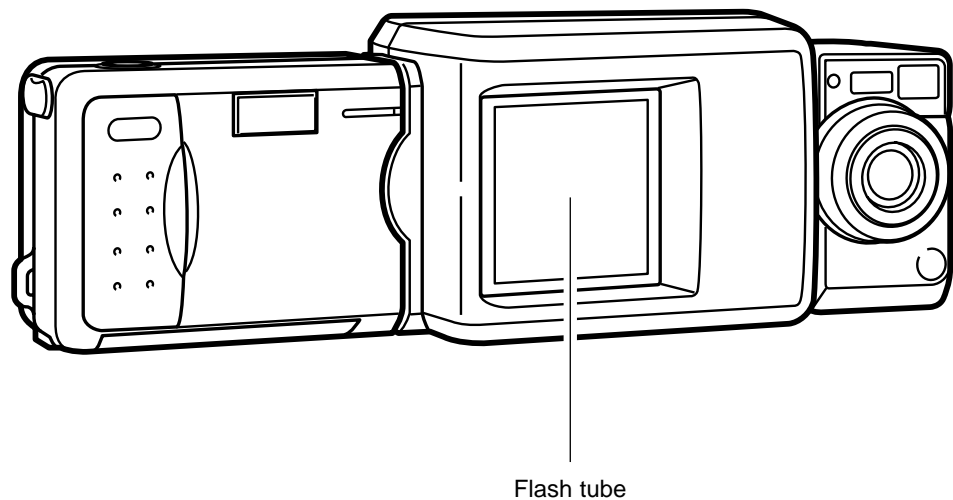

MATERIALS COVERED IN THIS MANUAL

This manual covers only the procedures for using the Minolta 3D 1500 to take pictures which will be served as the source for generating 3D images.

For the basic functions and operating procedures of the Minolta 3D 1500 camera, refer to the Camera Instruction Manual for Dimâge EX.

You can use your Minolta 3D 1500 as an ordinary Dimâge EX (Version 2) camera (non-3D camera) by attaching an optional Zoom 1500 or Wide 1500 lens unit in place of the MetaFlash unit. For the operating procedures for this purpose, refer to the Dimâge EX Camera Instruction Manual and "Dimâge EX Version 2 Guide" which come with the Dimage EX system.

PREPARATION

INSERTING BATTERIES [Camera Body]

The Minolta 3D 1500 uses a total of 8 AA-sized alkaline batteries, 4 batteries for the camera body and 4 batteries for the MetaFlash unit.

- You may also use AA-sized Ni-Cd or Ni-MH batteries.
- When using Ni-Cd or Ni-MH batteries, fully recharge them with a vendor-endorsed battery charger.

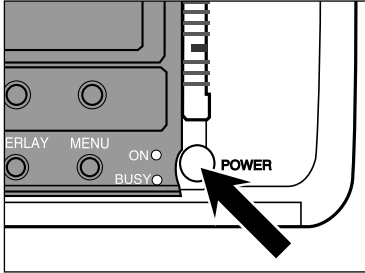

- 1** (When replacing the batteries), press the main switch to turn the camera off and remove the camera bracket (see Page 21).

- You may skip this step when inserting the batteries for the first time after purchase.

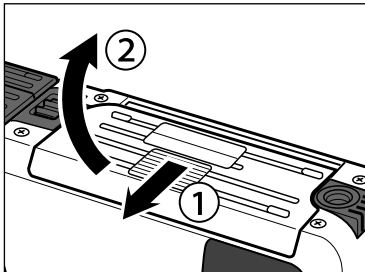
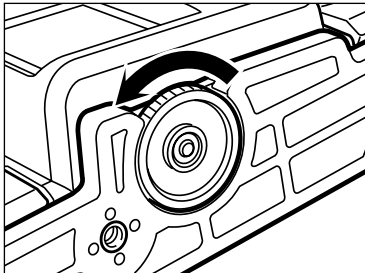

- 2** Open the battery-chamber cover by sliding it in the direction indicated, then open the cover.

INSERTING BATTERIES [Camera Body]

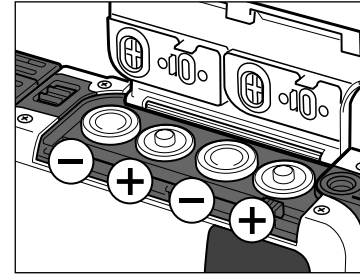

- 3** Insert the batteries as indicated by the +/- diagram on the back of the battery-chamber cover.

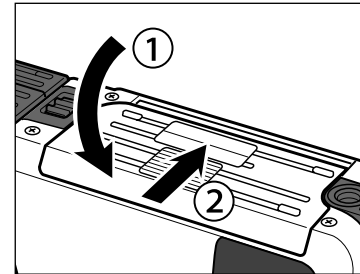

- 4** Close the battery-chamber cover and slide it shut until it clicks.

INSERTING BATTERIES [MetaFlash]

The Minolta 3D 1500 uses a total of 8 AA-sized alkaline batteries, 4 batteries for the camera body and 4 batteries for the MetaFlash unit.

- You may also use AA-sized Ni-Cd or Ni-MH batteries.
- When using Ni-Cd or Ni-MH batteries, fully recharge them with a vendor-endorsed battery charger.

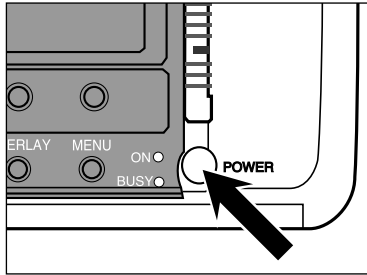

- 1** (When replacing the batteries), press the main switch to turn the camera off, turn the MetaFlash off, and remove the camera bracket (see Page 21).

- You may skip this step when inserting the batteries for the first time after purchase.

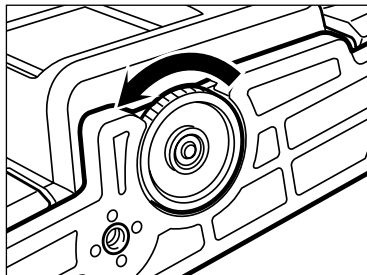
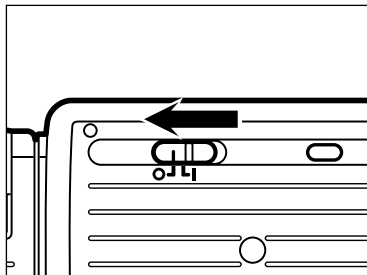

INSERTING BATTERIES [MetaFlash]

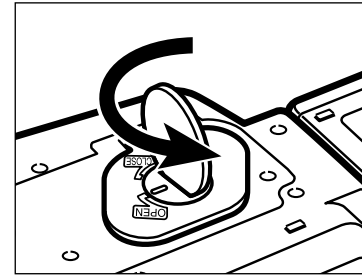

- 2** Using a coin or similar object, turn the battery-chamber lock counter-clockwise to the OPEN mark.

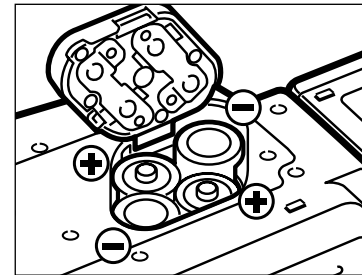

- 3** Open the battery-chamber cover, then insert the batteries as indicated by the + and - marks.

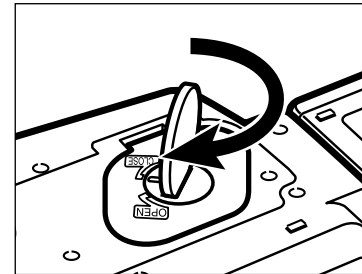

- 4** Close the cover, then turn the battery-chamber cover to the CLOSE mark to lock it.

- To prevent damage to the cover, do not place the camera body with the battery-chamber cover opened and the cover facing downward.

Low Battery Indicator [Camera Body]

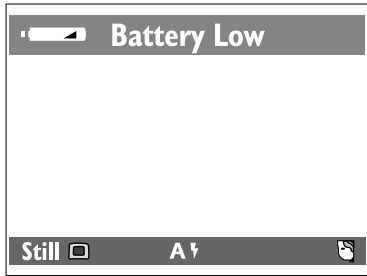

A warning message will appear in the top overlay bar of the LCD monitor when the battery power gets low.

In such a case, turn the camera off temporarily and replace the four batteries with new ones* or use the AC adapter.

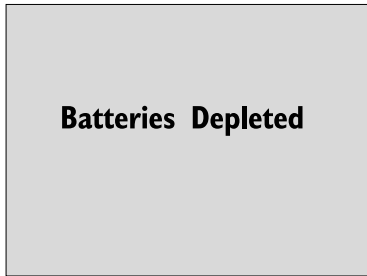

When the battery power is too low for camera operations, an alert dialog will appear on the LCD monitor.

You can not operate your camera under this situation. The camera will automatically shutdown in approximately one minute.

In such a case, turn the camera off immediately and replace the four batteries with new ones* or use the AC adapter.

* Take care when replacing the batteries as they are hot immediately after the camera is operated.

Rules of Thumb for Replacing the Batteries [MetaFlash]

Replace the batteries when the camera shows one of the following charging times (the time till the Flash-ready lamp on the rear panel turns on after taking a picture):

AA-sized alkaline batteries

30 seconds or longer → Replace all of the 4 batteries with new ones.

AA-sized Ni-Cd batteries

30 seconds or longer → Replace all of the 4 batteries with fully charged ones.

AA-sized Ni-MH batteries

30 seconds or longer → Replace all of the 4 batteries with fully charged ones.

Auto Power Off [Camera Body]

The LCD monitor will shut off if the camera has not been used for 3 minutes.

- The power lamp will remain on.
- Press the Display button to turn the LCD monitor back on.

After an additional 3 minutes without use (6 minutes total), the camera will shut down completely.

- The power lamp will turn off.
- Press the main switch to turn the camera back on.

✎ When you are using the AC adapter, the Auto Power Off feature will be activated and camera power is automatically shut off if you take no action for approximately 30 minutes or longer.

Auto Power Off [MetaFlash]

The MetaFlash unit is provided with no Auto Power Off feature. For power saving, turn off its power frequently when you are not to use the MetaFlash unit.

✎ Whenever you take a picture, make sure that your MetaFlash unit is switched on.

INSERTING BATTERIES - CONT'D

Using the AC Adapter [Camera Body Only]

Use the AC Adapter allows the camera to receive power from an electrical outlet. Use of the AC Adapter is recommended to conserve batteries during periods of heavy use. It is also recommended when interfacing the camera with the computer.

Always turn the camera off, and switch the digital camera power supply off, before changing from batteries to AC adapter or vice versa. Do not change the power supply while the camera is on.

- 1 Turn the camera off and remove all of the four batteries.

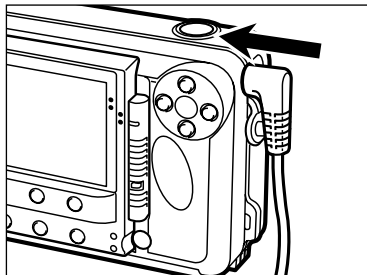

- 2 Insert the mini plug into the camera's DC terminal.

- The shape of the mini plug varies depending on the AC adapter.

- 3 Insert the AC plug into an electrical outlet.

COMPACT FLASH CARD

Your camera requires a compact flash card to be inserted before capturing images.

Always turn off the camera before inserting or removing the compact flash card into or from the camera.

The data in the card will be lost, or the card itself may be damaged, if the compact flash card is inserted or removed while the camera is on.

Inserting the Compact Flash Card

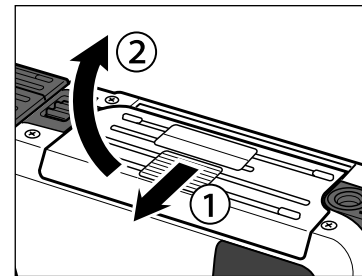

- 1 Open the battery-chamber cover by sliding it in the direction indicated, then open the cover.

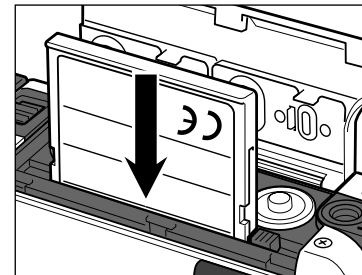

- 2 Insert the compact flash card into the card slot, pushing it in until the card-release lever pops out.

- Insert the card so the back label is on the lens side of the camera.
- Push the card in straight, not at an angle.
- Wrong direction: If the card stops mid-way, confirm the direction of the card. Do not force the card.

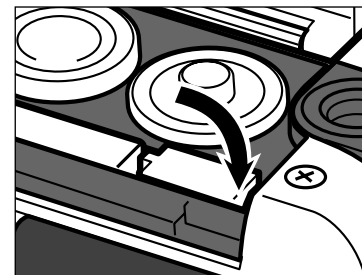

- 3 Fold the card-release lever down as shown.

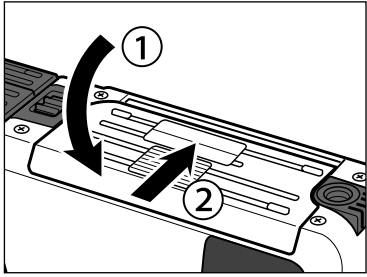

4 Close the battery-chamber cover and slide it shut until it clicks.

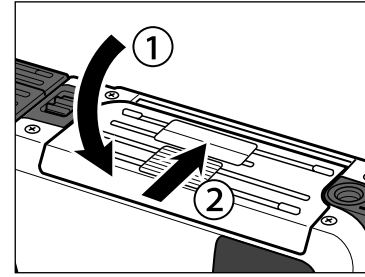

6 Close the battery-chamber cover and slide it shut until it clicks.

Removing the Compact Flash Card

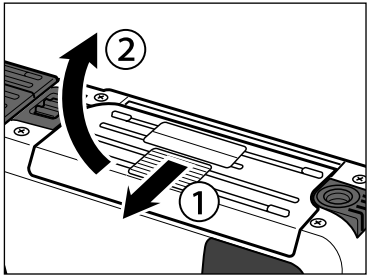

1 Make sure the camera is off.

2 Open the battery-chamber cover by sliding it in the direction indicated, then open the cover.

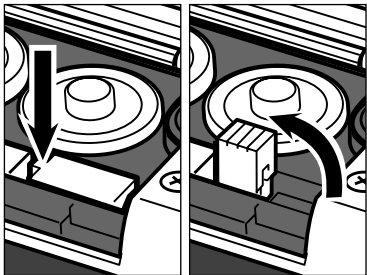

3 Lift the card-release lever until it is straight out.

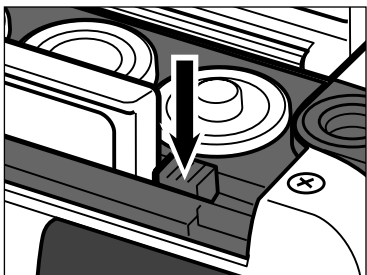

4 Press the card-release lever to eject the card.

5 Pull the compact flash card straight out.

Be careful not to open the card slot/battery chamber cover or disconnect the AC adapter cable while the camera is in use. The CF card can sustain damage if the camera loses power while data is being written to the card. In such a case, re-format the CF card on a personal computer after transferring the image data from the CF card to the personal computer.

ATTACHING AND REMOVING THE METAFASH UNIT

Attaching the MetaFlash Unit to the Camera

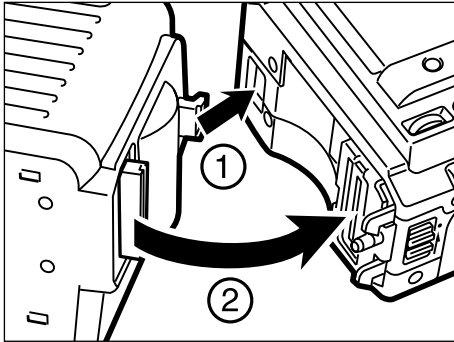

Align the projection on the MetaFlash Unit with the hole on the camera.
Fit the MetaFlash Unit in the direction of the arrow as shown until a click is heard.

Removing the MetaFlash Unit from the Camera

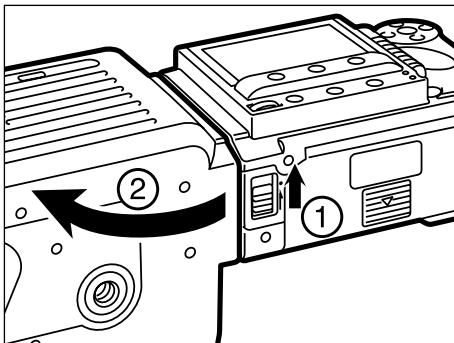

Slide and hold the MetaFlash Unit release on the bottom plate of the camera in the direction indicated and gently remove the MetaFlash Unit as shown.

ATTACHING THE CAMERA BRACKET

The CB-3D1 camera bracket stabilizes the positions of the camera body, MetaFlash unit, and lens unit. Using this bracket is very important when capturing 3D images.

1 Orient and mount the CB-3D1 camera bracket so that the positioning pin on the camera bracket fits in the tripod's screw hole in the camera body and the mounting screw in the tripod's crew hole in the Metaflash unit (see the figure below).

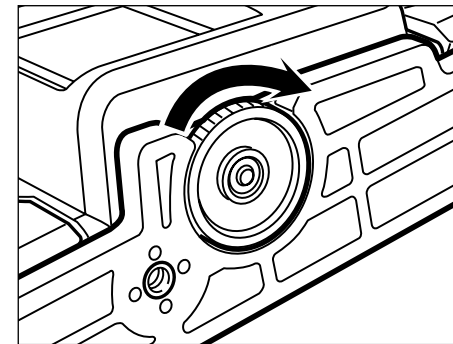
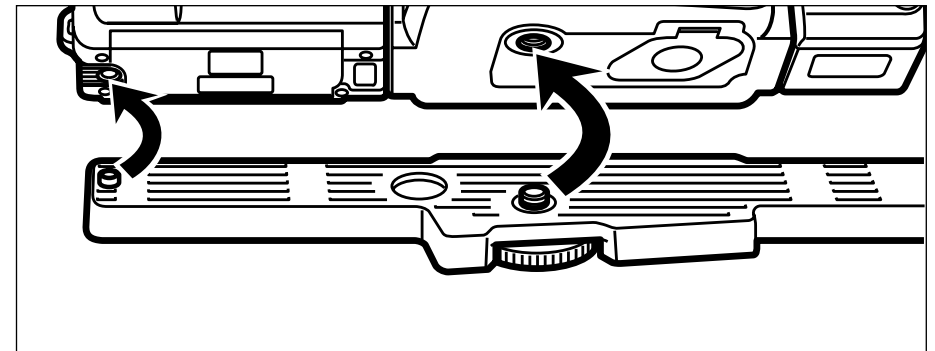

2 Turn the mounting screw in the direction of the arrow shown in the figure and secure it in place.

- When removing the camera bracket, loosen the bracket by turning it in the direction opposite to the one that is shown in the left figure.

PROCESSES FOR GENERATING A 3D IMAGE

[Image with no stripes projected]



[Image with stripes projected]

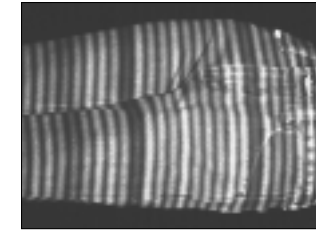

Calibration Data

<MetaFlash Studio>

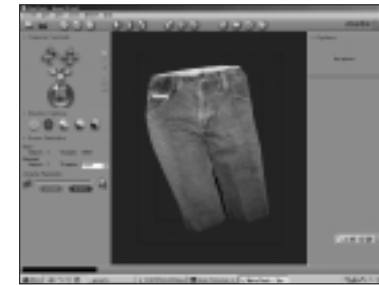

The Minolta 3D 1500 take two pictures as shown above during a single shot: one without a projected stripe and the other with projected stripes.

The two images of data are transferred to the personal computer where a 3D image is generated from the images by an application called MetaFlash Studio. The generated 3D image can be saved as 3D image files in different formats.

<Internet Explorer/Netscape Navigator>

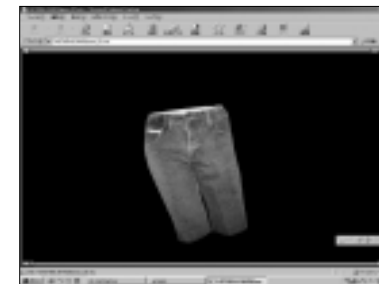

The 3D image can also be displayed with a Web browser (software for viewing web pages on the Internet) such as Internet Explorer or Netscape Navigator.

- *MetaStream Viewer Plug-In is required to have a 3D image displayed on a web browser.*

BEFORE TAKING PICTURES

The Minolta 3D 1500, unlike ordinary digital cameras, requires you to be aware of shooting-time restrictions and conditions. In particular, the following three items are essential for taking proper 3D-image pictures:

- **Subjects that are not suited for the 3D 1500**
- **Making the background of the subject solid black**
- **Brightness of the subject and its surrounding**

Subjects That are Not Suited for the 3D 1500

Generally, the following subjects are not suited as the subjects of shooting:

- **Transparent (passing the light) or highly reflective subjects**
- **Subjects that are evenly black or of a dark color**
- **Long and spidery subjects**
- **Subjects whose width, height, and depth are 40 cm or greater**
- **Subjects whose width, height, and depth are less than 10 cm**
- **Subjects of a complex shape with fine irregularities**

*The 3D 1500 emits two flashes in a single shot and records one "image without a projected stripe" and one "image with projected stripes" for the same subject. That is, it takes an ordinary flash photo on the first flash and projects the stripes on the second flash by perform masking before emitting the second flash. It becomes easier to generate proper 3D images if there will be 10 or more stripes on the subject. **Try to position the camera so that the subject fills the entire view area on the camera's LCD monitor.** Then there should be enough stripes on the subject.*

You can not generate effective 3D images for transparent (passing the light) or highly reflective subjects or subjects that are evenly black or of a dark color since such subjects can not accommodate clear stripes.

Making the Background of the Subject Solid Black

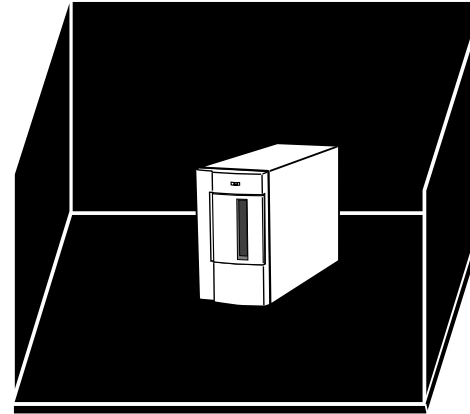

Make the background of the subject solid black with a plain black wrapping paper or black cloth to obtain optimum results.

As explained previously (see Page 24), the 3D 1500 can generate no 3D image from an evenly black subject. You can prevent the background (or the subjects in the background) from being caught by making the background of the subject solid black.

Neither black wrapping paper nor black cloth are necessary if the background (or the subjects in the background) are at least 4 m away from the camera and if they emit or reflect no light.

Brightness of the Subject and Its Surrounding

The 3D 1500 records pattern-projected images by emitting flashes into masked subjects. Consequently, it is necessary to keep the subject of shooting and its surroundings “evenly dark” when taking a picture.

More specifically, take care with the following:

- **Keep the subject of shooting and its surroundings “evenly dark.”**
More specifically, control the brightness so that it is lower than “**Bv - 1 or less**” in photographic terms (Bv -1 refers to the brightness that is equivalent to “a landscape at dawn or sunset”).

As another rule of thumb, keep such a brightness that the subject is recognizable but its details (letters on the subject) are illegible.

- **Do not use any lighting equipment that has a strong directivity such as spotlights.**
- **Do not take pictures during the day in the natural light (sun beam).**
- **Take care with reflections. Since reflections offset the flash beam, holes will develop in the parts of the image where the reflections occur.**

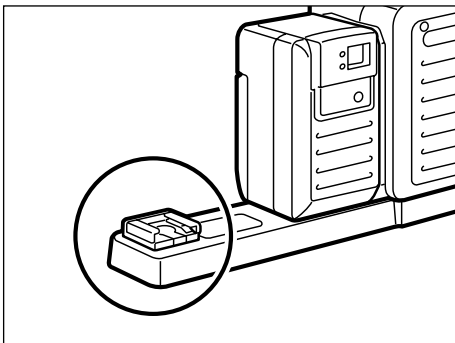

The CB-3D1 camera bracket is provided with a general-purpose hot shoe (see the left figure). Mount a commercial video light or similar apparatus there and turn on the video light when framing and focusing and turn it off when taking a shot, and you can take pictures even in a totally dark room.

To Get Better 3D Images

- **Position the camera so that the subject is centered in and completely fills the view area on your 3D 1500's LCD monitor.**
Making sure the subject completely fills the camera's view area is one of the most important steps in capturing an image.
- **Avoid creating shadows on the subject, whenever possible.**
Take special care with concave parts so that they provide no shade.
- **Be sure to make the background solid black.**
- **Longer axis of the object is recommended to be along the horizontal axis of the camera.**
- **Position the camera with angles in small increments and take as many shots as possible.**

TAKING PICTURES

1 Mount the 3D 1500 securely on a tripod.

- The 3D 1500 causes the MetaFlash unit to emit two flashes during a single shot. Any slight sway of the camera would hamper it from taking accurate pictures. Be sure to secure the 3D 1500 on the tripod.

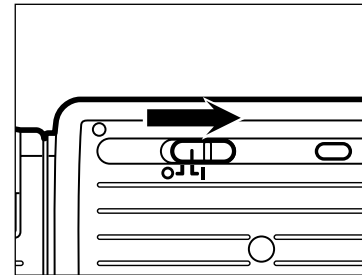

2 Turn the MetaFlash on.

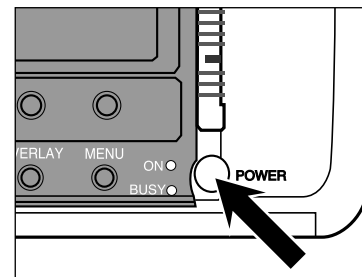

3 Press the main switch to turn the camera body on.

- An icon will appear on the soft key label (right side) indicating that the camera is now in the 3D mode.
- The lens unit automatically zooms to 50 mm in the 35 mm equivalent scale and gets locked there.
- The 3D 1500 enters the burst mode (2 frames fixed).
- The "Fill-Flash" icon appears on the soft key label (center). This icon indicates that not the camera's built-in flash but the MetaFlash is forced to emit flashes (the built-in flash unit is kept off in the 3D mode).

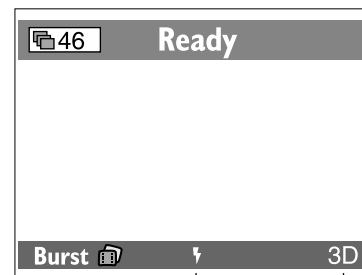

Fill-Flash Icon

Icon that identifies the 3D mode

Continued on Next Page

Steps **4** through **8** shown below are not necessary when using this camera for the first time. Proceed with step **9**.

Set “Quality” to “S.FINE (Super Fine)” in steps **4** to **8** when you used the 3D 1500 as an ordinary Dimâge EX (non-3D camera) by replacing the MetaFlash unit with a zoom 1500 or wide 1500 lens (optional) and you changed the “Quality” setting in the Burst mode.

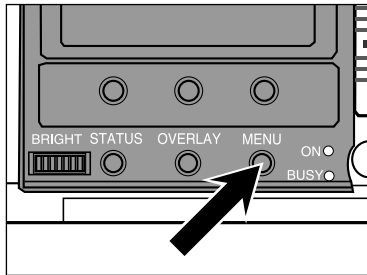

4 In Record mode, press the MENU button.

- The Record mode menus will appear.

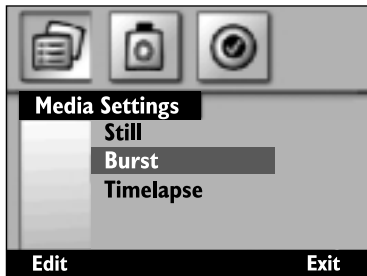

5 Press the Left or Right button to highlight “Media Settings”.

Press the Up or Down button to highlight “Burst”.

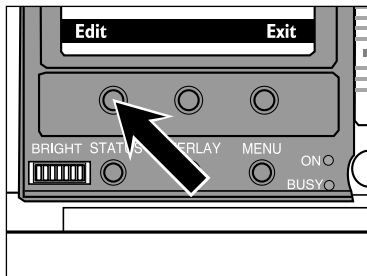

6 Press the Edit soft key.

- The “Burst Settings” menu will appear.

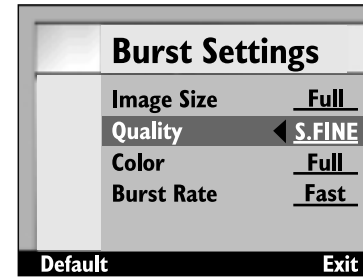

7 Press the Up or Down button to highlight “Quality”.

Press the Left or Right button to select “S.FINE”.

- “Image Size” is fixed at “Full” and can not be changed in the 3D mode.
- “Color” is fixed at “Full” and can not be changed in the 3D mode.
- You can set “Burst Rate” from the screen in the 3D mode but any change you made will not be reflected (the same burst capture rate is selected even if you selected any of “Fast,” “Medium,” and “Slow.”).

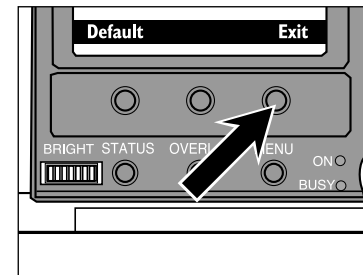

8 Press the Exit soft key twice.



9 Frame the subject so that the distance between the 3D 1500 and the subject falls between 50 to 90 cm and determine the composition while referring to the LCD monitor.

- Keep the subject as large as possible so that it fills the entire 3D 1500's LCD monitor screen.

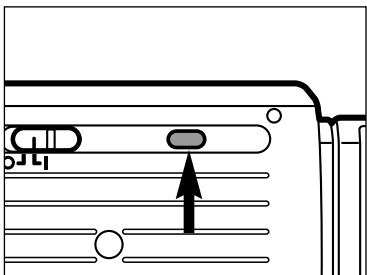

10 Make sure that the Flash-ready lamp on the MetaFlash unit turns on.

- You can click the shutter even when the MetaFlash unit is not fully charged. Be sure to check that the MetaFlash unit has been fully charged (the Flash-ready lamp is lit) before taking a picture.

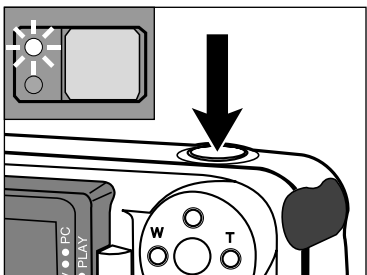

11 Press the shutter-release button part way down. When the green focus lamp glows, press the shutter-release button the rest of the way down to take a picture.

- In a dark situation, the built-in flash emits a small amount of light as a supplementary light source to illuminate the subject when you press the shutter-release button part way down.
- A Blinking green focus lamp indicates that the subject is out of focus. See Page 36 of the Dimâge EX Camera Instruction Manual.

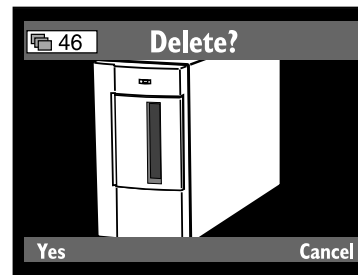
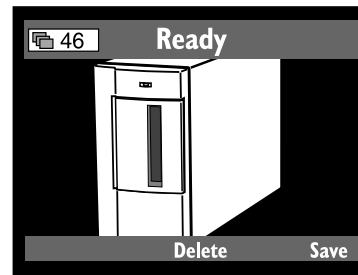

When the Instant Review is on, the screen shown in the upper left figure will appear every time you finish taking a picture.

- To record (save) the image on the CF card, press the **Save** soft key (soft key (right)).
- When not recording (saving) the image on the CF card, press the **Delete** soft key (soft key (center)). The confirmation screen shown in the lower left figure will appear. Press the **Yes** soft key (soft key (left)).
- You can disable the Instant Review feature if you find it cumbersome to select either Save or Delete every time you take a picture (in which case the image is recorded on the CF card immediately when you take a picture). For instructions, refer to Page 58 of the Dimâge EX Camera Instruction Manual.
- The LCD monitor is held off while the image you shot is being recorded. The monitor turns on again when recording (saving) is completed.

Any changes you made to the following items will be ignored in the 3D mode:

- Still Picture Settings
- Timelapse Settings
- White Balance Settings

The following functions remain disabled in the 3D mode:

- Bracketing
- Flash Bracketing

In general the camera sets the exposure setting automatically. But, if necessary, the exposure can be adjusted to make the final image brighter or darker. When the image turns out to be too dark or too bright, you can easily compensate for that by pressing the Up or Down button on the camera.

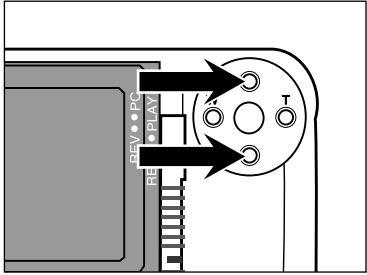

1 While in Record mode, press the Up or Down button to select the exposure compensation value.

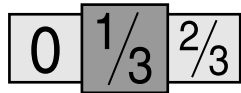
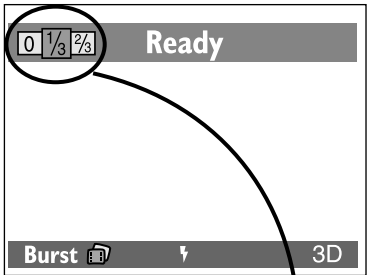

- The exposure compensation values are displayed in the upper-left corner of the LCD monitor, replacing the image counter.
- The exposure can be biased as much as +/- 2 EVs in 1/3 EV increments.
- The exposure change is visible in the LCD monitor.

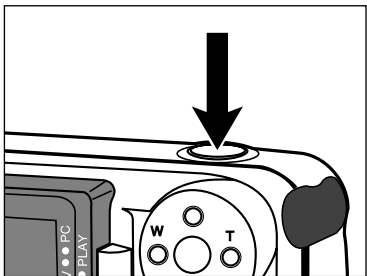

2 Frame the image, then press the shutter-release button.

- The exposure compensation value remains active after the picture is taken.

- Exposure can only be adjusted in Record mode. Set the exposure compensation before recording the image. Once the image is captured, it can not be changed in the camera.
- ✎ Reset the exposure compensation value to 0 when finished. The exposure compensation values do not remain in the overlay bar, but the exposure compensation value remains active.
- ✎ The exposure compensation value will return to 0 when you turn the camera off and turn it on again.

TRANSFERRING IMAGE DATA

When you finish taking necessary pictures, transfer the recorded image data from the CF card to a personal computer (PC) and generate 3D images using the MetaFlash Studio application program. There are two ways to transfer image data from a CF card to a PC.

(1) Transferring the image data with a CF card reader

Connect a card reader that has the capability to read CF card data directly and transfer image data to the PC through it.

 Refer to the instruction manual attached to the CF card reader for cabling and operating instructions.

(2) Transferring the image data via a PC card using a CF card and a PC card adapter

Insert the CF card into the (optional) CA-1C PC card adapter, and the CF card can be handled as a Type II PC card (PCMCIA-ATA card). Insert this PC card directly into the PC card slot of the notebook computer or into a card reader that can read PC card data, then transfer the image data to the PC through the PC card.

 Refer to the instruction manual attached to the notebook computer or PC card reader for operating instructions.

FOR YOUR INFORMATION

For further operating procedures for the PC (procedures for generating 3D images from the image data on the PC), refer to the instruction manual for MetaFlash Studio. The MetaFlash Studio's instruction manual is contained on the CD-ROM as a PDF file.

WHEN TO REPLACE THE XENON LAMP

The luminescent tube (xenon lamp) of the MetaFlash unit has a limited life. The Minolta 3D 1500 informs you when to replace the xenon lamp by turning on the self-timer lamp on the front of the camera body when the camera is turned on after 2000 shots (4000 flashes) are taken with the camera.

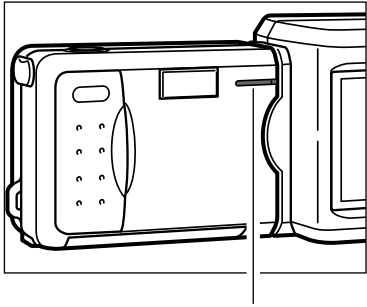

Self-timer lamp

- The self-timer lamp will not light when 2000 shots (4000 flashes) are reached while you are taking a shot. In this case, turn off and on the camera, and the self-timer lamp will light.
- You can continue taking pictures after the self-timer lamp turns on to indicate the replacement timing of the xenon lamp. It is recommended, however, that you call a Minolta Service Facility for replacement information as soon as possible.

WARNING

The replacement of the xenon lamp should be accomplished only at one of Minolta Service Facility. Any access to the high-tension component or circuit inside the 3D 1500 may cause electric shock.

The attached floppy disk contains a Script file "Getscnt.csm" that shows the total number of MetaFlash that have been fired so far on the LCD monitor of the 3D 1500. Use this Script to check the number of pictures that you can take before it becomes necessary to replace the xenon lamp. For instructions, read the Readme.txt file that is also contained on the floppy disk.

To run this Script, you need a system environment (e.g., CF card reader) for writing data on the CF card since it is necessary to copy the Script file from the floppy disk into the specified location on the CF card.

TROUBLESHOOTING

Refer to these pages to determine the cause of a problem you are experiencing with the camera. If the information does not cover the problem you are experiencing, contact our a Minolta Service Facility.

Problem	Cause	Solution
No image appears on the LCD monitor.	The camera is not turned on.	Press the main switch to turn the camera on and check that the power lamp goes on.
	The batteries are exhausted.	Replace all four batteries or use the AC Adapter.
	The batteries are inserted incorrectly.	Remove the batteries and replace in the correct orientation.
	The compact flash card is not inserted properly in the camera.	Remove the compact flash card temporarily and reinsert it.
No image appears on the LCD monitor (the power lamp is on).	No action was taken on the camera for longer than approximately 3 minutes after the camera is turned on.	Press the Display button on the lens unit.
	The LCD brightness has been turned down too low.	Turn the brightness dial to the desired level.

Problem	Cause	Solution
The camera will not take a picture.	The camera is off.	Press the main switch to turn the camera on and check that the power lamp goes on.
	The camera is not in Record mode.	Slide the Mode Switch to REC.
	The camera is processing, Please Wait appears in the overlay bar.	Wait until Ready appears in the overlay bar.
	The compact flash card is full, No space on card appears in the overlay bar.	Delete unwanted images, transfer card contents to the PC then erase the card, or use a new compact flash card.
It takes too long a time to charge the MetaFlash unit (30 seconds or longer).	The batteries in the MetaFlash unit are exhausted.	Replace all four batteries in the MetaFlash unit.
The intensity of the MetaFlash unit is too low (the self-timer lamp on the front of the camera stays on).	The xenon lamp has ended its life.	Contact a Minolta Service Facility for replacing the xenon lamp.
The image appears under- or overexposed.	Wrong exposure compensation setting.	Change the Exposure Compensation (EV) value.

Problem	Cause	Solution	
3D images will not be generated properly.	A subject that is ill suited for the 3D 1500 is used.	You can not obtain a proper 3D images when you take a picture of a subject that is ill suited for the 3D 1500.	
	A subject does not fill the view area on the LCD monitor.	Position the camera so that the subject is centered in and completely fills the view area on your 3D 1500's LCD monitor.	
	The background of the subject is not solid black.	Make the background of the subject solid black with an evenly blackwrapping paper or black cloth.	
	The subject or its surrounding is too bright.	Take a picture in a dark location (Bv -1 or lower).	
		Incorrect 3D reconstruction parameters in MetaFlash Studio software.	Follow MetaFlash Studio User Guide for selecting correct reconstruction parameters in Acquire MetaFlash dialog.
	The camera will not function normally.		Remove the batteries after opening the card slot/battery-chamber cover on the bottom plate of the camera body and reinsert them. If the camera got out of order while it was being powered by the AC adapter, unplug the AC adapter cable from the DC terminal and reconnect the cable. Subsequently, press the main switch to turn on the camera again.
		 <i>The CF card is likely to be damaged if you fails to shut off the camera power normally. In such a case, re-format the CF card on a personal computer after transferring the image data from the CF card to the personal computer.</i>	

The Minolta 3D 1500 is provided with optional accessories which are briefly described below. For more information, contact your camera dealer or Minolta Service Facility listed on the back cover of this manual.

ZOOM 1500 (Lens Unit)

ZOOM 1500 is a 1.5 million-pixel x3 zoom lens unit equivalent to a 35 mm f/3.5-5.6, 38-115 mm lens unit. You can use your 3D 1500 as an ordinary (non-3D camera) Dimâge EX (version 2) by replacing the 3D 1500's MetaFlash unit with the ZOOM 1500.

WIDE 1500 (Lens Unit)

WIDE 1500 is a 1.5 million-pixel wide angle lens unit equivalent to a 28 mm/F1.9 35 mm lens unit. You can use your 3D 1500 as an ordinary Dimâge EX (version 2) (i.e., non-3D camera) by replacing the 3D 1500's MetaFlash unit with the WIDE 1500.

LC-EX1 Lens Extension Cable

The LC-EX1 is a (1.5 m long) extension cable that connects between the detached MetaFlash unit and the camera body of the 3D 1500 system. You can take pictures with the MetaFlash unit separate from the camera body so that you can photograph from a variety of angles. The LC-EX1 can also be used with a 3D 1500 which is used as an ordinary Dimâge EX (version 2) (i.e., non-3D camera).

ⓘ The AF illuminator derived from the camera's built-in flash unit is not available when the LC-EX1 is used.

VC-EX1 Video Cable

The VC-EX1 Video Cable connects between the video output of the 3D 1500 and the video input of a TV set or video deck. It is used to show the information on the LCD monitor of the 3D 1500 on a TV screen or to record it on a video deck. The VC-EX1 can also be used with a 3D 1500 which is used as an ordinary Dimâge EX (version 2) (i.e., non-3D camera).

RM-8C/RM-16C/RM-32C compact flash Cards

The RM-8C, RM-16C, and RM-32C are compact flash cards with storage capacities of 8MB, 16MB, and 32MB, respectively.

CA-1C PC Card Adapter

The CA-1C is a PC card adapter that turns a compact flash card into a PC card. By combining the CA-1C with a compact flash card, you can use the compact flash card as a PC card (Type II) which conforms to the ATA PC Card Standard.

Operating Temperatures and Conditions

- This camera has been designed for use from 10°C to 30°C (50°F to 86°F).
- Never leave the camera where it may be subjected to extreme temperatures, such as the glove compartment of a car.
- Do not subject the camera to extreme humidity.
- To prevent condensation from forming, place the camera in a sealed, plastic bag when bringing it from the cold exterior to a warm building. Allow it to come to room temperature before removing it from the bag.
- Battery performance decreases with lower operating temperatures. When photographing in cold weather, it is recommended that you keep the camera and spare batteries inside your coat to keep them warm when you are not shooting. Cold batteries will regain some of their charge when they warm up.
- Occasionally, when using alkaline batteries the low-battery symbol may appear even if there is enough charge. Continue to use the camera. The low-battery symbol will disappear.

Handling Care

- This camera is neither waterproof nor splashproof.
 - Inserting/removing batteries or CompactFlash cards with wet hands may damage the camera.
 - Take care when using the camera at the beach or near water. Costly or irreparable damage may occur.
- Do not subject the camera to shock or impact.
- Do not leave the camera in direct sunlight. Do not point the lens at direct sunlight. CCD damage may occur.
- Turn the camera off or remove the batteries when transporting.

Lcd Monitor Care

- The LCD monitor is a precision device with a pixel efficiency of 99.98%. Less than 0.02% of the pixels are dysfunctional.
- Do not apply pressure on the surface of the LCD monitor. Permanent damage may occur.
- In low temperatures, the LCD monitor will temporarily darken. When the camera warms-up, normal display will be restored.
- If the + or – buttons are pressed rapidly during playback, images may appear to overlap. This is normal and the image data is not changed.
- If the LCD monitor surface is dirty, first blow away dust or sand, then gently wipe it with a soft, clean, dry cloth.
- If the LCD display blinks continuously or no longer works at all, it is time to replace the monitor. Take the camera to your dealer or a Minolta Service Facility listed on the back cover of this manual.

Safety and Handling for Compact Flash Cards

- Read and follow the instructions that accompanied the compact flash card.
- The following may cause data loss or damage:
 - Improper use of card.
 - Static electrical discharge near card or electric noise.
 - Removing the card or interrupting power supply while camera or drive is accessing the card (reading, deleting, etc.).
 - Non-use of card for an extended period. Data stored on compact flash cards will degrade over time. Data left on a card for extensive periods may not be recoverable.
 - Wear from ordinary use.
- The storage capability of compact flash cards will diminish with extended use. When this occurs, please purchase a new card.
- Do not bend, drop, or subject the card to impact.
- Keep away from static electricity and electric noise.
- When not in use, return the card to its protective case.
- All data on the card is permanently erased when the card is formatted.
- Do not touch the electrical contacts of the card with your fingers or a metal object.
- Keep away from heat, moisture, and direct sunlight.
- Keep away from small children.

CARE AND STORAGE - CONT'D

Cleaning

- If the camera or lens is dirty, gently wipe it with a soft, clean, dry cloth. If the camera or lens comes in contact with sand, gently blow away loose particles, wiping may scratch the surface.
- To clean the lens surface, first brush away any dust or blow away sand, then, if necessary, moisten a lens tissue with lens cleaning fluid and gently wipe the lens.
- Never use organic solvents to clean the camera.
- Never touch the lens surface with your fingers.

Storage

- Remove the batteries from the camera when not in use for an extended period. Damage may result if battery leakage occurs.
- Store in a cool, dry, and well-ventilated area away from dust and chemicals (such as mothballs). For very long periods, place the camera in an airtight container with a silica gel drying agent.
- Before using after prolonged storage, check the camera's operation to make sure it is functioning properly.

Before Important Events

- Always check the camera's operation carefully or take test photographs.
- Minolta is not responsible for damages incurred by equipment malfunction.

Questions and Service

- If you have questions about your camera, contact your local camera dealer or write to the Minolta distributor in your area.
- Before shipping your camera for repair, please contact a Minolta Service Facility for details.

TECHNICAL DETAILS

Camera Type

MetaFlash type 3D image capture system

CCD

1/2 inch progressive scan CCD (SONY "Wfine CCD™")

Model: Square pixel, RGB primary color filter, all pixel simultaneous readout system

Total number of pixels: Approx. 1,500,000 pixels

Number of effective pixels: Approx. 1,450,000 pixels

Lens Unit

Focal length: 9.5 mm (in the 35mm film equivalent scale)

Aperture: FNo. 4

Construction: 5 elements, 5 group zoom including 3 aspheric surfaces

Focusing range: 50 cm to 90 cm

Viewfinder: Real-image optical viewfinder

Image Storage

Recording medium: CompactFlash card

Image file format: Exif 2.0 (JPEG)

Number of pixels: 1344 x 1008 pixels

Image quality modes: S.FINE, FINE, STD, ECON

File size: S.FINE mode — Approx. 3 MB per folder (2 images contained in a folder) (Approx. 1.5 MB per image)

Number of folders: Approx. 10 when recorded on a 32MB CF card in the S.FINE mode

Autofocusing

System: External passive AF system

Focus locked when the shutter-release button is pressed halfway, with AF auxiliary light source using the camera's built-in flash unit under low brightness conditions

Exposure Control

Electronic shutter speed: 1/210 second, fixed

Aperture value: F4, fixed

Exposure compensation: Up to ± 2 EV in 1/3 EV increments

Sensitivity: ISO100 equivalent

White Balance

Fixed at the color temperatures of the MetaFlash unit

MetaFlash

Flash mode: Fill-flash, fixed

Light control: External light control using the light-controlling element in the lens unit.

Charging time: Approx. 10 seconds maximum (when new alkaline batteries are used)

Xenon lamp life: Approx. 2000 shots (4000 flashes)

Alert issued on 2000 shots (40000 flashes).

Replaceable at a Minolta Service Facility

Built-in Flash

Serves as a supplementary AF light source in the low-brightness mode.

Viewfinder

A real-image optical viewfinder is provided in the lens unit.

LCD Monitor

Type: 2.0-inch low temperature poly-silicon color TFT-LCD module

Pixels: Approx. 110,000

Brightness control: Brightness control dial

Drive mode

2-frame burst capture mode

Power source (camera body)

Power: AA-sized alkaline battery x 4 (AA-sized Ni-Cd or AA-sized Ni-MH batteries are also available).

External power: AC adapter (a DC terminal is provided on the camera body.)

Power source (MetaFlash unit)

Power: AA-sized alkaline battery x 4 (AA-sized Ni-Cd or AA-sized Ni-MH batteries are also available).

Battery life: Approx. 2000 shots (4000 flashes)

Operating Ambient Temperature and Humidity Ranges

10 to 30°C (50 to 86°F), 85% maximum (noncondensing)

Dimensions (W x H x D)

240 x 77 x 76 mm (9.5 x 3.1 x 3.0 inches)

Weight (without batteries)

Approx. 600 g (21.2 oz.)

Specifications are based on the latest information available at the time of printing and are subject to change without notice.

MEMO

A large, empty, rounded rectangular box with a thin black border, occupying most of the page area below the header and above the footer. It is intended for handwritten notes or a memo.

MEMO

A large, empty, rounded rectangular box with a thin black border, occupying most of the page area below the header and above the footer. It is intended for handwritten notes or a memo.

MEMO

A large, empty rounded rectangular box with a thin black border, occupying most of the page area below the header and above the footer.

MEMO

A large, empty rounded rectangular box with a thin black border, occupying most of the page area below the header and above the footer.

MEMO

A large, empty, rounded rectangular box with a thin black border, occupying most of the page area below the header and above the footer. It is intended for handwritten notes or a memo.

MEMO

A large, empty, rounded rectangular box with a thin black border, occupying most of the page area below the header and above the footer. It is intended for handwritten notes or a memo.

MEMO

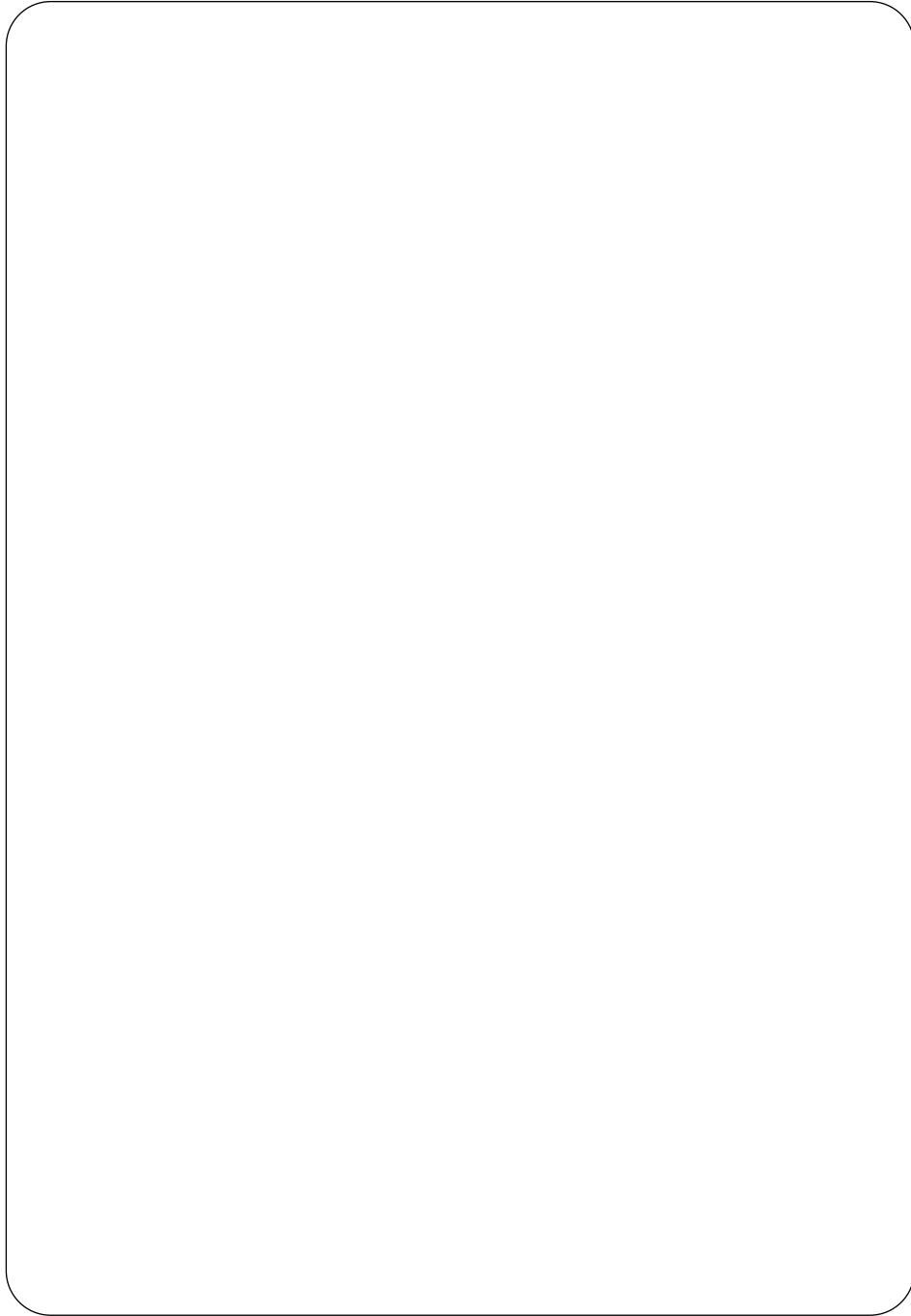

MINOLTA

MINOLTA 3D 1500

Minolta Co., Ltd.	3-13, 2-Chome, Azuchi-Machi, Chuo-Ku, Osaka 541-8556, Japan
Minolta Corporation	
Head Office	101 Williams Drive, Ramsey, New Jersey 07446, U.S.A.
Los Angeles Branch	11150 Hope Street Cypress, CA 90630, U.S.A.
Minolta Canada Inc.	
Head Office	369 Britannia Road East, Mississauga, Ontario L4Z 2H5, Canada
Minolta GmbH	Kurt-Fischer-Strasse 50, D-22923 Ahrensburg, Germany
Minolta France S.A.	365 Route de Saint-Germain, F-78420 Carrières-Sur-Seine, France
Minolta (UK) Limited	7 Tanners Drive, Blakelands, Milton Keynes, MK14 5BU, England
Minolta Austria Ges. m.b.H.	Amalienstrasse 59-61, A-1131 Wien, Austria
Minolta Camera Benelux B.V.	Zonnebaan 39, P.O. Box 6000, NL-3600 HA Maarssen, The Netherlands
Belgium Branch	Prins Boundewijnlaan 1, B-2550 Kontich, Belgium
Minolta (Schweiz) AG	Riedstrasse 6, CH-8953 Dietikon, Switzerland
Minolta Svenska AB	Albygatan 114, S-171 54 Solna, Sweden
Finland Branch	Niittykatu 6 PL 37, SF-02201 Espoo, Finland
Minolta Portugal Limitada	Av. do Brasil 33-A, P-1700 Lisboa, Portugal
Minolta Hong Kong Limited	Room 208, 2/F, Eastern Center, 1065 King's Road, Quarry Bay, Hong Kong
Minolta Singapore (Pte) Ltd.	10, Teban Gardens Crescent, Singapore 608923

E Camera Instruction Manual

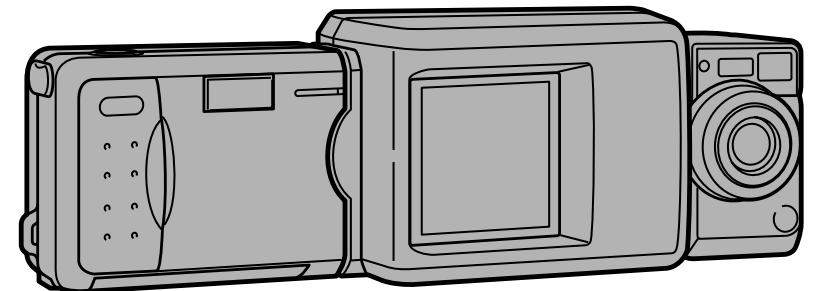

© 1999 Minolta Co., Ltd. under the Berne
Convention and Universal Copyright Convention

metaflash
by MetaCreations