

MULTI-FUNCTION RECORDING

FULL-TIME AF

With full-time AF active, the autofocus systems continually focuses to keep the monitor image sharp. This also reduces the autofocusing time when taking pictures. Full-time AF can be activated in the custom 1 section of the multi-function recording mode menu (p. 50).



When the monitor is turned off or when the camera is set to manual focus, full-time AF is disabled. Turning the full-time AF function off can help conserve battery power.

METERING MODES

The icons indicating both metering modes are displayed on the monitor only. The metering mode is set in the custom 1 section of the multi-function recording mode menu (p. 50).

Multi-segment metering uses 270 segments to measure luminance and color. This data is combined with distance information to calculate the camera exposure. This advanced metering system will give accurate worry-free exposures in almost all situations.

Spot metering uses a small area within the image to calculate the exposure. When this mode is selected, the LCD monitor will automatically activate if off and a small circle will appear in the middle of the live image indicating the measuring area. The spot allows precise exposure measurements of a particular object without being influenced by extremely bright or dark areas within the scene. If the LCD monitor is turned off, the spot-metering mode will remain active.

LCD monitor	Data panel	
	-	Multi-segment
		Spot metering



EXPOSURE BRACKETING

In multi-function recording mode, the bracketing increment can be changed in three steps: 0.3 Ev, 0.5 Ev, 1.0 Ev. The larger the number, the greater the difference in exposure between the images in the bracketed series. For information on the bracketing drive mode, see page 36. The bracketing increment can be changed in the custom 1 section of the multi-function recording mode menu (p. 50).

DIGITAL ZOOM AND IMAGE SIZE

The digital zoom doubles the lens magnification (p. 22). The digital zoom can be disabled in the custom 1 section of the multi-function recording mode menu (p. 50).

When an image is taken with the digital zoom, the final image size depends on the image-size setting on the camera. The image is trimmed and then the total number of pixels are recalculated to produce an image with a pixel resolution shown in the chart.

	Image size setting			
	2272 X 1704	1600 X 1200	1280 X 960	640 X 480
Size of recorded image	1024 X 768	1024 X 768	1024 X 768	640 X 480

MULTI-FUNCTION RECORDING

IMAGE CONTROL - COLOR, SHARPNESS, CONTRAST, & SATURATION

Changes in color, sharpness, contrast, and saturation can be made using the custom 2 section of the multi-function recording mode menu (p. 50). These imaging controls give photographers the ability to maximize the image information at the scene. For example, if a scene is too contrasty, information can be lost in the shadows and highlights; decreasing the contrast will bring out more detail.

Any changes made with these functions are applied to the live image on the monitor. The color mode, sharpness, contrast, and color saturation levels must be set before the image is recorded. If sharpness, contrast, or color saturation is set to any setting other than normal, an icon will be displayed indicating an increase (+) or decrease (-) in the quality selected. Turning the camera off will not reset these functions; they must be manually reset using the menu.



Unlike the display on a computer, changes made with sharpness, contrast, and color saturation may be difficult to see on the LCD monitor. However, when viewed with imaging software, the changes will be evident.

	Color mode	To select between 24-bit color and 8-bit monochrome images. It has no effect on image file size.
	Sharpness	To accent or soften details in an image in three levels: hard (+), normal, and soft (-).
	Contrast	To increase or decrease the contrast of the scene in three levels: high (+), normal, and low (-).
	Color saturation	To accent or subdue the color of a scene in three levels: high (+), normal, and low (-).

BULB EXPOSURES

Bulb photographs can be taken in the manual-exposure mode (M) (p. 53). Exposures up to fifteen seconds can be made by pressing and holding the shutter-release button. The use of a tripod is recommended for bulb exposures.

Set the exposure mode to manual in the basic section of the multi-function recording mode menu (p. 50). Set the drive mode to single-frame advance (p. 32).

Use the controller (1) to decrease the shutter-speed value below four seconds until "bulb" is displayed.

To set the aperture value, press the exposure-compensation button (2); the aperture display should turn blue. Use the controller (1) to set the aperture.

- The camera's exposure system cannot be used to calculate bulb exposures. The use of a separate light meter is recommended.

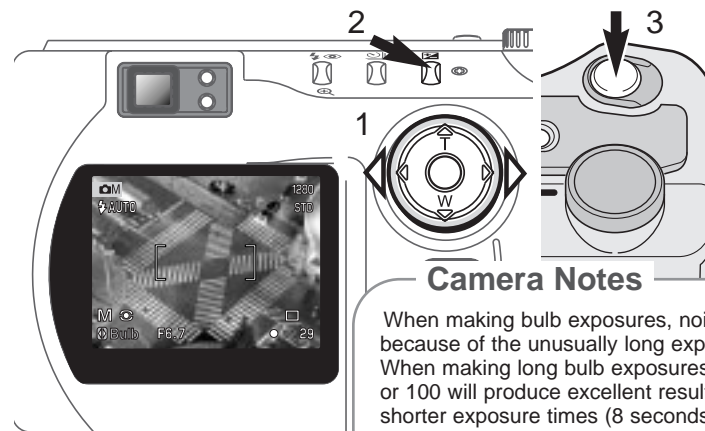

To take the picture, press and hold the shutter-release button (3) for the duration of the exposure.

- Releasing the shutter button will end the exposure.
- The monitors will be blank during the exposure.

Camera Notes

When making bulb exposures, noise can be more pronounced because of the unusually long exposure times, especially at 400 ISO. When making long bulb exposures, a camera sensitivity setting of 64 or 100 will produce excellent results. At higher ISO settings, using shorter exposure times (8 seconds or less) will reduce the effect of noise.

A SHORT GUIDE TO PHOTOGRAPHY

Photography can be a rewarding pursuit. It is a broad and disciplined field that can take years to master. But the pleasure in making photographs and the joy of capturing a magical moment cannot be compared. This guide is an introduction to some basic photographic principles.

The lens aperture controls not only exposure, but also depth of field; the area between the closest object in focus and the furthest object in focus. The larger the aperture value, the greater the depth of field and the longer the shutter speed needed to make the exposure. The smaller the aperture value, the shallower the depth of field and the faster the shutter speed needed to make the exposure. Usually landscape photographs use a large depth of field (large aperture value) to keep the foreground and background in focus, and portraits use a shallow depth of field (small aperture value) to separate the subject from the background.



Depth of field also changes with focal length. The wide-angle position of the lens has a large depth of field; the telephoto position has a shallow depth of field.

The shutter controls not only exposure, but also the ability to stop motion. Fast shutter speeds are used in sport photography to stop action. Slow shutter speeds can be used to show the flow of motion such as water cascading over a waterfall. The use of a tripod is recommended with slow shutter speeds.



The change in aperture and shutter speed is not apparent in the live image. Unlike film cameras, test photographs can be taken and immediately viewed. For critical work, take a test photograph at the set aperture or shutter speed and view the result in quick view (p. 26). The image can be deleted if not acceptable and another test image can be taken at a different setting.

MOVIE RECORDING

This camera can record up to sixty seconds of digital video with sound. The motion JPEG image is 320 X 240 pixels (QVGA). The effective image area is 284 X 211 pixels; two thin lines will appear to the left and right of the image when played back. Under certain conditions less than sixty seconds of digital video may be recorded.

Total recording time with an 16MB CompactFlash card is approximately 52 seconds. The digital video recording rate is approximately 0.23MB per second. Actual CompactFlash card capacity depends on the subject and the number of still images captured.

In movie recording, some functions can be used, some are fixed, and some are disabled. Exposure compensation (p. 46) and macro mode (p. 28) can be used. The focus mode is set to AF; the autofocus area is set to wide; the exposure mode is set to program; camera sensitivity and white balance is set to auto. The flash and digital zoom is disabled. This mode has no menu controls.



Before recording, the data-panel and monitor frame counters will show the maximum time in seconds can be recorded with the next movie clip. A maximum of 60 seconds will be displayed until the amount of remaining time falls below one minute, then the remaining number of seconds that can be recorded will be displayed.



Shooting digital video is simple. Set the main dial to movie recording (1). Frame the picture as described in the basic recording operation section (p. 23). Press the shutter-release button partway down to lock the focus. Press the shutter-release button all the way down and release to start recording (2). The zoom and focus are fixed during recording. The camera will continue to record until the recording time is used or the shutter-release button is pressed again. When recording, the data panel and monitor frame counters will count down the remaining time.

RECORDING MOVIES WITH THE RC-3 REMOTE CONTROL

The RC-3 remote control (sold separately) can be used to record movie clips up to 5m (16ft) away. Simply point the remote control toward the camera and use the release or delay button to start and stop the recording.

When using the release button (1), the self-time lamp will blink once before the camera starts to record; when using the delay button (2), the self-timer lamp will blink for two seconds before recording. The lamp will glow to indicate the camera is recording. Both buttons will stop the camera instantly when pressed. The remote control may not operate with backlit subjects or under fluorescent light.

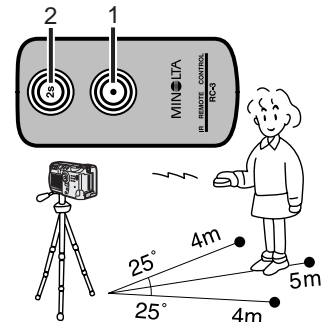

PLAYBACK MODE



VIEWING AND EDITING IMAGES

This section contains detailed information on the camera's playback functions and operation. Read the sections pertaining to your interest and need. The viewing pictures, viewing movies, deleting images (p. 68 - 69), the navigating the playback-mode menu (p. 72), and frame-selection screen (p. 81) sections cover the use of most of the features for viewing and editing images. The navigating the playback-mode menu section is followed by detailed descriptions of the settings.

SINGLE-FRAME PLAYBACK DISPLAY

Mode indicator  1280 Image size (p. 40)
 STD Image quality (p. 41)

Time of capture 14:20
 Date of capture 2002.04.27 [0029/0078]

Voice-memo icon (p. 43) 
 Lock icon (p. 75) 
 Print icon (p. 78) 

Frame number/total number of images

 To view the histogram of the displayed image, press the up key.

HISTOGRAM DISPLAY

1280 Image size (p. 40)
 STD Image quality (p. 41)
 1/1000 Shutter speed
 F3.0 Aperture value
 AWB White-balance setting (p. 54)
 39400 Camera sensitivity setting (p. 57)
 0 Degree of exposure compensation (p. 46)
 MLT12 Folder name (p. 100)
 100-0003 Folder number - image file number

 To return to single-frame playback, press the down key.

The histogram shows the luminance distribution of the recorded image from black (left) to white (right). Each one of the 256 vertical lines indicates the relative proportion of that light value in the image. The histogram can be used to evaluate exposure, but displays no color information.

MOVIE PLAYBACK DISPLAY

Mode indicator  ● : play

Playback time 23s

To view the movie, press the controller. 

14:20
 2001.07.20  [0029/0078]

Time of recording Date of recording Frame number/total number of images in folder

PLAYBACK MODE

VIEWING PICTURES

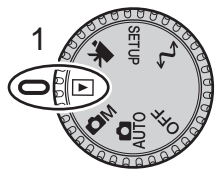

Still images and movie clips can easily be viewed and edited in playback mode. To set the camera to view images, turn the mode dial to the playback position (1).

Simply use the controller to scroll through the pictures on the CompactFlash card. The date and time of capture, frame number, printing status, lock status, image size and image quality are displayed with the images. The histogram and shooting data of a still image can also be displayed. The first frame of each movie clip is shown; a movie clip is indicated by the movie icon displayed with a thumbnail of the first frame.



Use the left/right keys of the controller to scroll through the images.



Press the up key to display the histogram of a still image.

- The left/right keys are disabled when the histogram is displayed. Press the down key to return to the playback mode.

Controller

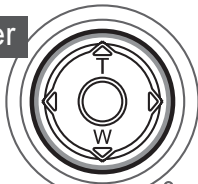

To play back a voice memo accompanying a still image, press the center of the controller.

- A note icon indicates if the image has an audio track.
- To cancel the audio playback, press the down key.



MENU



QV/delete button



VIEWING MOVIES



Use the left/right keys of the controller to display the movie clip to be viewed.



Press the center of the controller to play back the clip.

- Pressing the controller during playback will pause the movie clip; pressing the controller again will resume the playback. When the movie clip finishes, the first frame will be displayed.
- Press the display button to view the movie with or without the guidance bar.

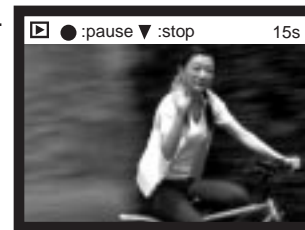

To cancel the playback of a movie, press the down key of the controller.

DELETING IMAGES

In playback mode, the displayed image or movie clip can be deleted. When selecting an image for deletion, a confirmation screen will appear before the operation is executed.

Once deleted, an image cannot be recovered.
Care should always be taken when deleting images.



- To delete a displayed image, press the QV/delete button.
- A confirmation screen will appear.



- Use the left/right keys to highlight "YES."
- "NO" will cancel the operation.



Press the controller to delete the image.

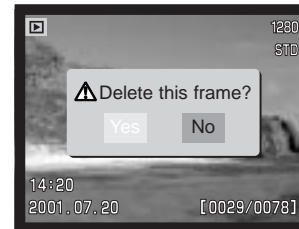

Confirmation screen

PLAYBACK MODE

DISPLAY BUTTON - PLAYBACK MODE

The display button controls the display format. Each time the button is pressed, the display cycles through to the next format: full display, image only, index playback.

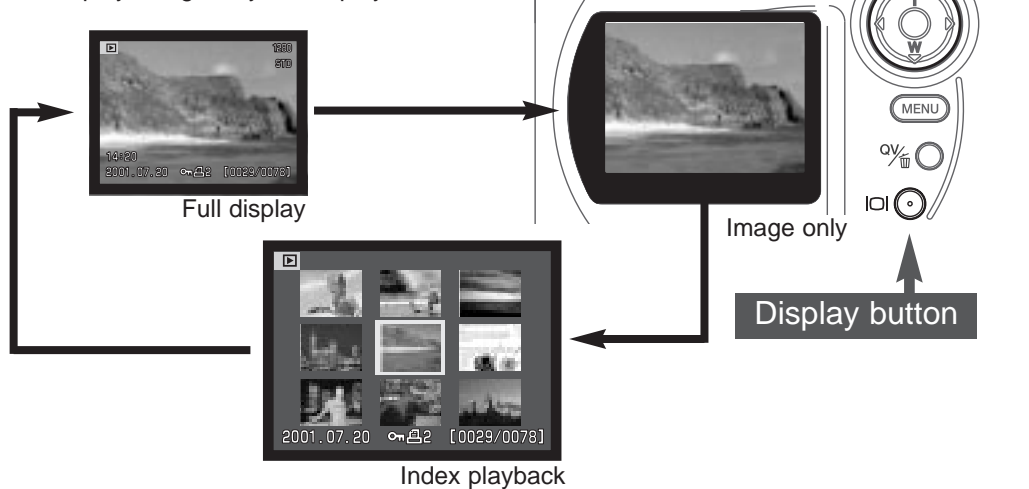

In index playback, the left/right keys of the controller will move the yellow border to the next or the previous image. When the image is highlighted with the border, the date of recording, voice memo icon, the lock and printing status, and the frame number of the image are displayed at the bottom of the screen. The highlighted image can be deleted using the QV/delete button (p. 69), or an accompanying voice memo can be played by pressing the controller. When the display information button is pressed again, the highlighted image will be displayed in the single-frame playback mode. A nine or four image index can be changed in the basic section of the playback-mode menu (p. 72).

ENLARGED PLAYBACK



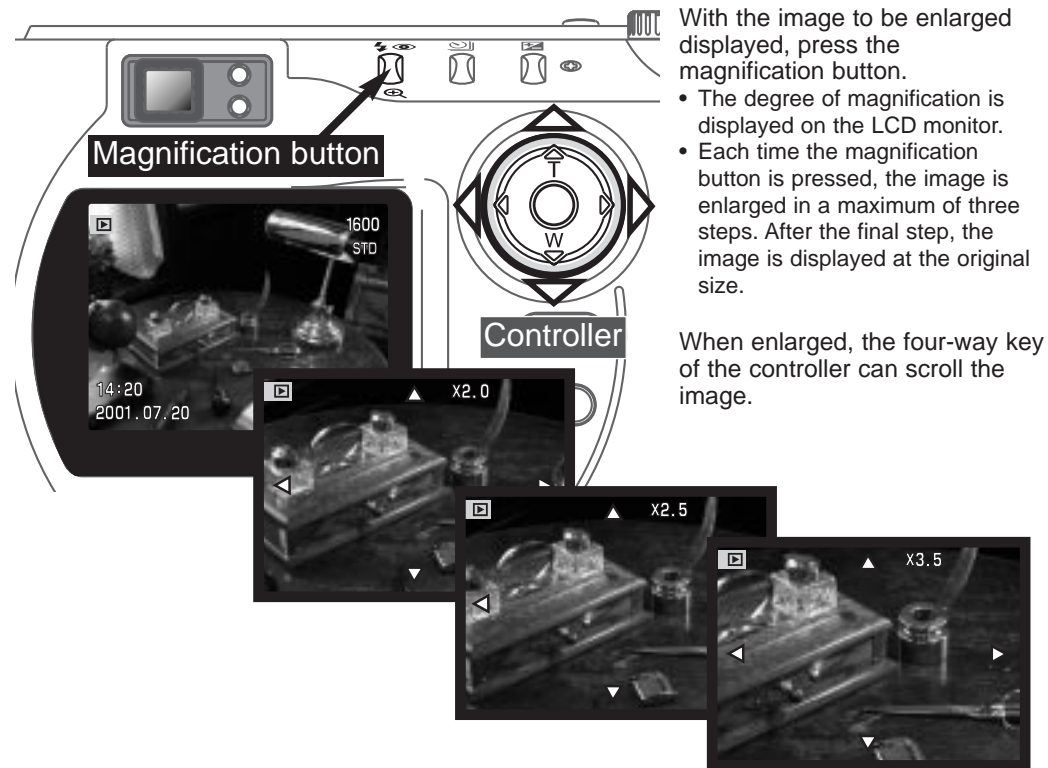

In single-frame playback, a still image can be enlarged for closer examination in three steps: 2x, 2.5X, and 3.5X. 640 X 480 size images can only be enlarged one step to 2X. The maximum enlargement of 1024 X 768 digital zoom images is 3.2X. Super fine images cannot be enlarged.



PLAYBACK MODE

NAVIGATING THE PLAYBACK-MODE MENU

In playback mode, press the menu button to activate the menu. The menu button also turns off the menu after making settings. The four-way keys of the controller are used to move the cursor in the menu. Pressing the center of the controller will enter a setting.

-  Activate the playback-mode menu with the menu button. The "Basic" tab at the top of the menu will be highlighted. Use the left/right keys of the controller to highlight the appropriate menu tab; the menus will change as the tabs are highlighted.
-  When the desired menu section is displayed, use the up/down keys to scroll through the menu options. Highlight the option whose setting needs to be changed.
 - When scrolling in one direction, the cursor will jump between the top and bottom of the menu.
-  With the menu option to be changed highlighted, press the right controller key; the settings will be displayed with the current setting highlighted.
 - To return to the menu options, press the left key.
-  Use the up/down keys to highlight the new setting.

 Press the controller to select the highlighted setting.

Once a setting has been selected, the cursor will return to the menu options and the new setting will be displayed. Changes can continue to be made. To return to the playback mode, press the menu button.

Controller

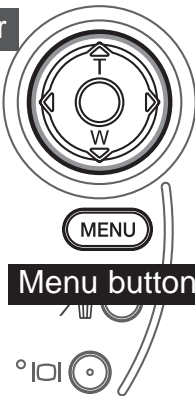

Menu button

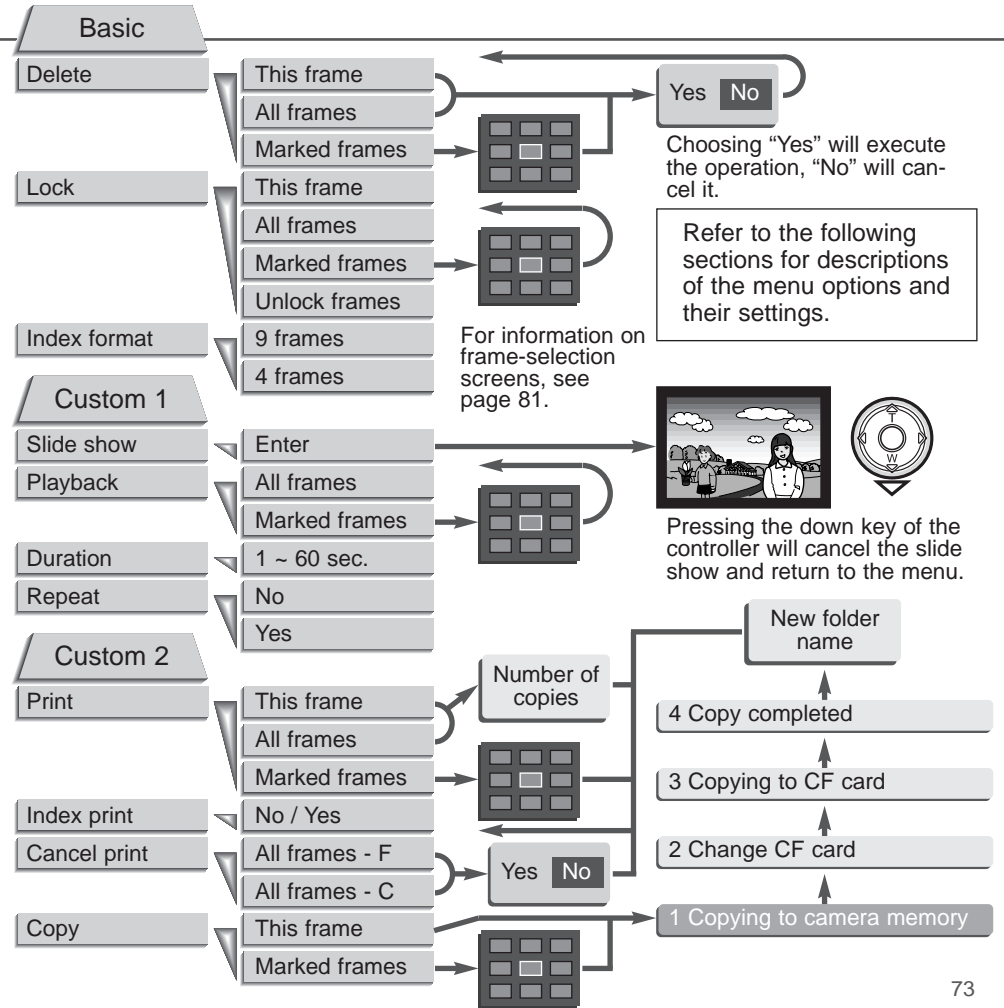

PLAYBACK MODE

PLAYBACK-MODE MENU - BASIC

DELETING IMAGES

Deleting permanently erases the image. Once deleted, an image cannot be recovered. Care should be taken when deleting images.

Single, multiple, or all images in a folder can be deleted with the playback-mode menu. Before an image is deleted, a confirmation screen will appear; choosing “Yes” will execute the operation, “No” will cancel the operation. To delete images in other folders, the folder must first be selected in the custom 1 section of the setup menu (p. 84). The delete option has three settings:

This frame - The image displayed or highlighted in playback mode will be deleted.

All frames - All unlocked images in the selected folder will be deleted.

Marked frames - To delete multiple images. When this setting is chosen, the frame-selection screen will be displayed. Use the left/right keys of the controller to highlight the first image to be deleted. Pressing the up key will mark the image with the garbage-can icon. To deselect an image for deletion, highlight it with the yellow border and press the down key; the garbage-can icon will disappear. Continue until all the images to be deleted are marked. Press the controller to continue (the confirmation screen will appear), or press the menu button to cancel the operation and return to the playback menu. On the confirmation screen, highlighting and entering “Yes” will delete the marked images.

The delete function will only erase unlocked images. If an image is locked, it must be unlocked before it can be deleted.

LOCKING IMAGES

Single, multiple, or all images in a folder can be locked. A locked image cannot be deleted by either the playback-mode menu functions or the QV/delete button. Important images should be locked. To lock images in other folders, the folder must first be selected in the custom 1 section of the setup menu (p. 84). The lock option has four settings:

This frame - The image displayed or highlighted in playback mode will be locked.

All frames - All images in the folder will be locked.

Marked frames - To lock or unlock multiple images. When this setting is chosen, the frame-selection screen will be displayed. Use the left/right keys of the controller to highlight the image to be locked. Pressing the up key will mark the image with the key icon. To unlock an image, highlight it with the yellow border and press the down key; the key icon will disappear. Continue until all the images to be locked are marked. Press the controller to lock the marked frames, or press the menu button to cancel the operation and return to the playback menu.

Unlock frames - All images in the folder will be unlocked.

Locking an image will protect it from a delete function. However, the formatting function (p. 86) will erase all images on a CompactFlash card whether locked or not.

CHANGING THE INDEX PLAYBACK FORMAT

The index format option allows the index playback to be displayed with four or nine images. This affects all index displays.

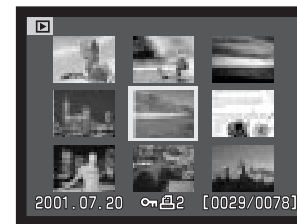

PLAYBACK MODE

PLAYBACK-MODE MENU - CUSTOM 1 (SLIDE SHOW)

The custom 1 section of the playback-mode menu controls the slide-show function. This function automatically displays all still images in a folder in order.



[009/028] — Frame count-down / total number of images in the presentation.



Press the controller to pause and restart the presentation.



To cancel the presentation, press the down key of the controller.

Menu options	Settings	
Slide show	Enter	To start the slide-show presentation. Pressing the center of the controller will pause the presentation. During the slide show, press the down key of the controller to stop the presentation and return to the playback-mode menu.
Playback	All frames	To select all the images in the folder to be displayed in the slide-show presentation.
	Marked Frames	To select specific images in the folder to be displayed in the slide-show presentation. When this setting is chosen, the frame-selection screen will be displayed. Use the left/right keys of the controller to highlight the image to be included in the presentation. Pressing the up key will mark the image with a check icon. To deselect a marked image, highlight it with the yellow border and press the down key; the check icon will disappear. Continue until all the images have been edited. Press the controller to set the marked frames, or press the menu button to cancel the operation and return to the playback menu.
Duration	1 - 60s.	To select the period each image will be displayed during the slide show.
Repeat	Yes / No	Selecting "Yes" will cause the slide show to repeat until it is canceled using the down key of the controller. "No" will end the slide show presentation and return to the playback-mode menu when all the images have been displayed once.

PLAYBACK MODE

PLAYBACK-MODE MENU - CUSTOM 2

ABOUT DPOF

This camera is supported by DPOF™ version 1.1. The DPOF (Digital Print Order Format) allows direct printing of still images from digital cameras. After the DPOF file is created, the CompactFlash card is simply taken to a photofinishing service or inserted into the CompactFlash-card slot of DPOF compatible printers. When a DPOF file is created, a misc. folder is automatically made on the CompactFlash card to store it (p. 100).

CREATING A DPOF PRINT ORDER

The print menu option is used to set an order for standard prints from images in a specific folder. Single, multiple, or all images can be printed. If a CompactFlash card has multiple folders, a printing file must be created for each folder. Folders are selected in the custom 1 section of the setup menu (p. 84).

This-frame - To create a DPOF file for the image displayed or highlighted in playback mode.

All-frames - To create a DPOF file for all images in the folder specified in the custom 1 section of the setup menu (p. 84).

Marked frames - To chose a group of images to be printed or when the number of copies for each image varies. When selected, the frame selection screen will appear. Use the left/right keys of the controller to highlight an image to be printed. Pressing the up key will mark the image with the printer icon. The number next to the icon indicates the number of copies of that image will be printed. Pressing the up key will increase the number of copies, pressing the down key will decrease the number. A maximum of nine copies can be ordered. To deselect an image for printing, press the down key until the the number of copies reaches zero and the printer icon disappears. Continue until all the images to be printed are marked. Press the controller to create the DPOF file, or press the menu button to cancel the operation and return to the playback menu.

When the this-frame or all-frames setting is chosen, a screen will appear requesting the number of copies of each image; a maximum of nine copies can be ordered. Use the up/down keys of the controller to set the number of copies desired. If the all-frames setting was used to create a print order, any additional images saved afterwards in the folder will not be included in the order.

DPOF files cannot be created for images captured with another camera. DPOF data created on other cameras will not be recognized.

ORDERING AN INDEX PRINT

To create an index print of all the images in the folder, select “Yes.” To cancel an index print, simply change the setting to “No.” If an index-print order is created, any additional images saved afterwards in the folder will not be included in the index print. The number of images printed per sheet differs between printers. The information printed with the thumbnails can vary.



CANCELING A DPOF PRINT ORDER

The cancel-print option deletes the DPOF files. When the setting is selected, a confirmation screen will appear; choosing and entering “Yes” will execute the operation and cancel the print order. After the pictures have been printed, the DPOF file will still remain on the CompactFlash card and must be canceled manually.

All frames C - To cancel all printing files on the CompactFlash card.

All frames F - To cancel the printing file in the folder. Folders are selected in the custom 1 section of the setup menu (p. 84).

PLAYBACK MODE

COPYING IMAGES

Image files can be copied from one CompactFlash card to another. Up to 23MB of data can be transferred. Every time the copy function is used, a new folder is automatically created for the images (p. 100). Images with voice memos are copied with their audio files. Copies of locked images are unlocked (p. 75). DPOF information is not copied.

This frame - To copy the image displayed or highlighted in playback mode.

Marked frames - To copy single or multiple images. When selected, the frame-selection screen will appear; highlight the image to be copied with the yellow border and then press the up key of the controller to mark it with the check icon. To deselect an image to be copied, highlight the selected image and press the down key; the check icon will disappear. Continue until all the images to be copied are marked. Press the controller to continue, or press the menu button to cancel the operation and return to the playback menu.

When the image(s) to be copied are selected, a screen with four messages is displayed; the messages are highlighted during the copying procedure. When the change-CF-card message is highlighted, remove the camera's CompactFlash card and insert the card to which the image should be copied. Press the center of the controller to continue or the menu button to cancel the copy operation. After the copy-completed message is highlighted, a new screen will appear to indicate the name of the new folder containing the copied images; press the controller to return to the menu.

If too many images have been selected, a warning will appear and the copy routine will be canceled. Divide the number of images into two or three batches. The copy-unsuccessful message will appear when one or all of the images could not be copied. Check the second CompactFlash card to see which files were copied and then repeat the procedure for the images that were not transferred.

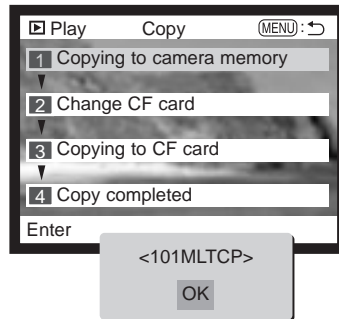

FRAME-SELECTION SCREEN

When a marked-frames setting is chosen on a menu, the frame selection screen will appear. This screen allows multiple images to be chosen. The index format of the screen can be changed in the basic section of the playback-mode menu (p. 72).





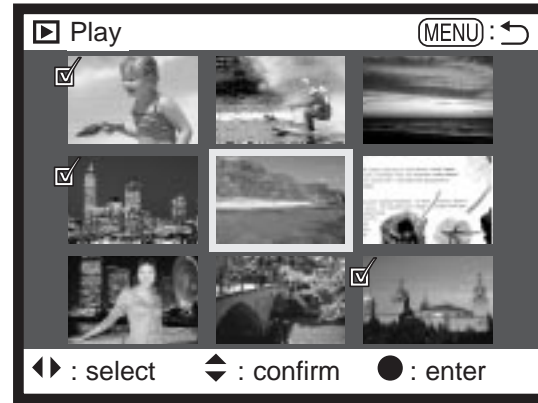

The left/right keys of the controller move the yellow border to select the image.



Menu button
Cancels the screen and any operation made.



The up key of the controller selects the frame; when selected, an icon will appear next to the image. The down key will deselect the image removing the icon.

	The garbage-can icon indicates the image is selected for deletion.
	The key icon indicates the image is locked or selected to be locked.
	The check icon indicates the image is selected for the slide show or to be copied to another CompactFlash card.
	The printer icon indicates the image is selected for printing. The number next to the icon shows the number of copies requested.

PLAYBACK MODE

VIEWING IMAGES ON A TELEVISION

It is possible to view camera images on your television. The camera has a video-out terminal to make the connection using the supplied AV cable. The camera is compatible with the NTSC and PAL standards. The video-output setting can be checked and set in the custom 2 section of the setup menu (p. 84).

1. Turn off the television and the camera.
2. Insert the mini-plug end of the AV cable into the camera's video-out terminal.
3. Plug the other end of the AV cable into the video and audio input terminals on the television.
 - The yellow plug is for the video output. The white plug is for the monaural audio output.
 - The audio output will also be heard through the camera's speaker while connected to a television.
4. Turn the television on.
5. Change the television to the video channel.
6. Turn the camera's mode dial to the playback position.
 - The camera's monitors will not activate when the camera is attached to a television. The playback-mode display will be visible on the television screen.
7. View images as described in the playback section.

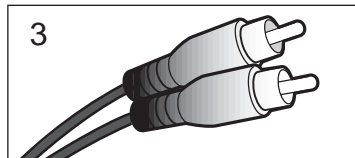
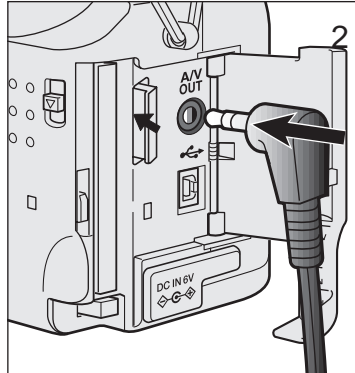

SETUP MODE CONTROLLING THE CAMERA'S OPERATION

The setup mode is used to control the camera's functions and operation as well as to select image folders. The navigating the setup menu section (p. 84) covers the operation of the menu. The section is followed by detailed descriptions of the settings.

Minolta History



Innovation and creativity has always been a driving force behind Minolta products. The Electro-zoom X was purely an exercise in camera design. It was unveiled at Photokina in Germany in 1966.

The Electro-zoom X was an electronically controlled aperture-priority mechanical SLR with a built-in 30 - 120mm f/3.5 zoom lens giving twenty 12 X 17mm images on a roll of 16mm film. The shutter-release button and battery chamber are located in the grip. Only a few prototypes were built making it one of Minolta's rarest cameras.

SETUP MODE

NAVIGATING THE SETUP MENU

To access the menu, simply turn the mode dial to the setup position. The four-way keys of the controller are used to move the cursor in the menu. Pressing the controller will enter a setting.



When the menu activates, the "Basic" tab at the top of the menu will be highlighted. Use the left/right keys of the controller to highlight the appropriate menu tab; the menus will change as the tabs are highlighted.



When the desired menu section is displayed, use the up/down keys to scroll through the menu options. Highlight the option whose setting needs to be changed.

- When scrolling in one direction, the cursor will jump between the top and bottom of the menu.



With the menu option to be changed highlighted, press the right controller key; the settings will be displayed with the current setting highlighted.

- To return to the menu options, press the left key.



Use the up/down keys to highlight the new setting.



Press the controller to select the highlighted setting.

Once a setting has been selected, the cursor will return to the menu options and the new setting will be displayed. Setting can continue to be made.

Controller

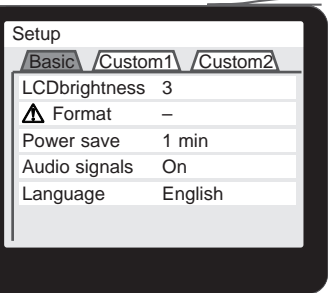
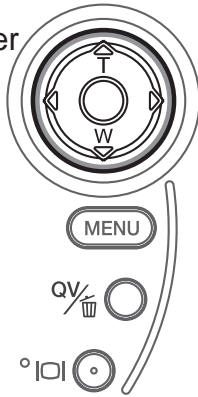

Basic	
LCDbrightness	1 (low) ~ 5 (high)
Format	Enter
Power Save	1, 3, 5, or 10 min
Audio signals	Off
	w/o sound FX
	Sound FX only
	On
Volume	1 (low) ~ 3 (high)
Language	Japanese
	English
	Deutsch
	Français
	Español

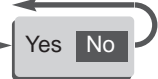

Choosing "Yes" on the confirmation screens will execute the operation, "No" will cancel the operation.

Please refer to the following sections for descriptions of the menu options and their settings.

Custom 1	
File # memory	On / Off
Select folder	(Folder names)

Custom 2	
Reset default	Enter
Date/Time set	Enter
Date format	YYYY/MM/DD
	MM/DD/YYYY
	DD/MM/YYYY

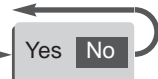

On the date/time setting screen, use the left/right key of the controller to select the year, month, day, hour, or minute. The up/down key is used to change the value. Press the controller to set the calendar and clock.

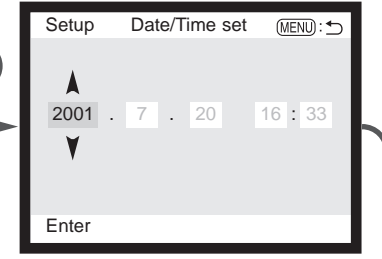

Video output	NTSC
	PAL

SETUP MODE

SETUP MENU - BASIC

The basic section of the setup menu allows changes to be made to the operation of the camera as well as the ability to format CompactFlash cards.

LCD MONITOR BRIGHTNESS

The brightness of the LCD monitor can be set in five levels from 1 (low) to 5 (high). As each setting is highlighted, the monitor will adjust accordingly; the controller must be pressed to set the highlighted level.

FORMATTING COMPACTFLASH CARDS

When a CompactFlash card is formatted, all data on the card is erased.

The formatting function is used to erase all data on a CompactFlash card. Before formatting a CompactFlash card, copy the data to a computer or storage device. Locking images will not protect them from being deleted when the card is formatted. Always format the CompactFlash card using the camera; never use a computer to format a card.

When the format option is selected and entered, a confirmation screen will appear. Choosing "Yes" will format the card, choosing "No" will cancel the formatting operation. A screen will appear to indicate the card has been formatted; press "OK" to return to the setup menu.

If the card-not-recognized message appears, the inserted card in the camera may need to be formatted. A CompactFlash card used in another camera may have to be formatted before being used. If the unable-to-use-card message appears, the card is not compatible with the camera and cannot be formatted.

AUTO POWER SAVE

The camera will turn off the data panel to conserve battery power if no operation is made within a certain period. The length of this period can be changed to 1, 3, 5, or 10 minutes. The auto-power-save option will not affect the display period of LCD monitor; it will shut down after 30 seconds. To restore the displays when they shut down, simply press the shutter-release button.

When the camera is connected to the computer, the auto-power-save period is set to ten minutes. This period cannot be changed.

AUDIO SIGNALS

The audio signal can be turned off or on. When on, both tones signals and sound effects are used. The sound effects simulates a film camera when the shutter is released. The sound effects and tones can be turned off independantly of each other.

Menu setting	
Off	All audio signals are turned off.
w/o sound FX	Tone signals only to indicate camera operations.
Sound FX only	Shutter effect only. No tone signals during operation.
On	Shutter effect and tone signals.

VOLUME

The speaker volume can be increased or decreased. This affects the audio signals only and will not change the levels of the voice memo or movie audio track.

LANGUAGE

The language used in the menus can be changed.

SETUP MODE

SETUP MENU - CUSTOM 1

The custom 1 section of the setup menu controls file number sequencing and the selection of folders. See page 100 for information on the organization of the folders on the CompactFlash card

FILE NUMBER (#) MEMORY

When file number memory is selected, if a new folder is created, the first file stored in the folder will have a number one greater than the last file saved. If the file number memory is disabled, the image file name will have a number one greater than the last image saved in the folder.

If file number memory is active and the CompactFlash card is changed, the first file saved to the new card will have a number one greater than the last file saved on the previous card if the new card does not contain an image with a greater file number. If it does, the file number of the new image will be one greater than the greatest on the card.

SELECT FOLDER

This option allows the selection of existing folders. After folder is selected, all images recorded will be placed in that folder. In quick view or playback mode, only the images in the selected folder can be viewed or edited.

Except for the all-frames-C setting in the custom 2 section of the playback-mode menu, changes made with menus only affect the images in the selected folder. To make changes to all images in multiple folders, each folder must be selected and the menu operation repeated for each folder. Formatting a CompactFlash card erases all folders regardless if they are selected or not.

SETUP MENU - CUSTOM 2

RESETTING THE CAMERA

This function affects all modes. When selected, a confirmation screen will appear; choosing “Yes” resets the following functions and settings, “No” cancels the operation.

	Default Setting	Page
Exposure mode	Program	52
Focus mode	Autofocus	56
Focus area	Wide focus area	48
Digital zoom	On	22
Drive mode	Single-frame advance	32
Flash mode	Auto flash	30
Image quality	Standard	41
Image size	2272 X 1704	40
Voice memo	Off	43
Date imprinting	Off	44
Instant playback	Off	45
Metering mode	Multi-segment	58
Exposure compensation	0.0	46
Camera sensitivity (ISO)	Auto	57
White balance	Auto white balance	54
Exposure bracket	0.5 Ev	59
Color mode	Color	60

Continued on next page

SETUP MODE

	Default Setting	Page
Sharpness	Normal	60
Contrast	Normal	60
Color-saturation	Normal	60
Index playback format	9 frames	75
Duration (Slide Show)	5 seconds	76
Repeat (Slide Show)	No	76
Index print	No (Canceled)	79
LCD monitor brightness	3	86
Auto-power-save period	1 minute	87
Audio signals	On	87
File number memory	Off	88

SETTING THE DATE AND TIME

It is important to accurately set the clock. When a still image or a movie clip is recorded, the date and time of the recording are saved with the image and are displayed during playback or can be read with the DiIMAGE Image Viewer Utility software included on the CD-ROM. The camera's clock is also used with date imprinting (p. 44).

When the Date/Time-set option is selected and entered, the date/time screen will be displayed. The left/right keys of the controller are used to select the item to be changed and the up/down keys are used to change the value. From left to right, the screen shows the year, month, day, hour, and minute. When the date and time have been adjusted, set the clock by pressing the center of the controller.

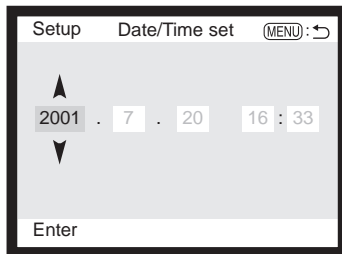

SETTING THE DATE FORMAT

The date format that is displayed or imprinted can be changed: YYYY/MM/DD (year, month, day), MM/DD/YYYY (month, day, year), DD/MM/YYYY (day, month, year). Simply select the format and enter it by pressing the center of the controller; the new format will be displayed on the menu.

VIDEO OUTPUT

Camera images can be displayed on a television (p. 82). The video output can be changed between NTSC and PAL. North America uses the NTSC standard and Europe uses the PAL standard. Check which standard is used in your region to play back images on your television set.

Minolta History

On February 20th, 1962, John Glenn became the first American to orbit the Earth. On board his Friendship 7 spacecraft was a Minolta Hi-matic camera to record that historic event. The 4 hour, 55 minute, and 23 second flight orbited the Earth three times at an average speed of 28,000 kph (17,500 mph).

Mr. Glenn visited our Sakai camera factory in Japan on May 24th, 1963 to plant a palm tree to celebrate the occasion. The palm tree is still in the courtyard of the factory and stands over eight meters tall (26ft).

The camera? It was not lost. It is on display at the Smithsonian Institution's National Air and Space Museum in Washington D.C. This and other objects from John Glenn's Friendship 7 Mercury flight can be found in galley 210, "Apollo to the Moon."



DATA-TRANSFER MODE

CONNECTING TO A COMPUTER

Read this section carefully before connecting the camera to a computer. Details on using and installing the DiMAGE Image Viewer Utility software are found in the supplied software manual. The DiMAGE manuals do not cover the basic operation of computers or their operating systems; please refer to the manual supplied with your computer.

For the camera to be connected directly to the computer and used as a mass-storage device, the computer must be equipped with a USB port as a standard interface. The computer and the operating system must be guaranteed by their manufacturers to support USB interface. The following operating systems are compatible with the camera:

IBM PC / AT Compatible	Macintosh
Windows 98, 98SE, Me, 2000 Professional, and XP.	Mac OS 8.6 ~ 9.2.1 and Mac OS X 10.1

Users with Windows 98 or 98 second edition will need to install the driver software on the included DiMAGE software CD-ROM (p. 67). Users with Mac OS 8.6 will need to download and install a USB mass-storage device from the Apple web site (p. 70).

Customers who have bought a DiMAGE 7, 5, S304, X, or 2330 digital camera and have installed the Windows 98 driver software must repeat the installation procedure. The updated version of the driver software included on the supplied DiMAGE software CD-ROM is required for the operation of the DiMAGE X with a computer. The new software will have no affect on the performance of the DiMAGE 7, 5, S304, X, or 2330.

ARCSOFT PHOTOIMPRESSION SYSTEM REQUIREMENTS

IBM PC / AT Compatible	Macintosh
Pentium-based computer	Power PC
Windows 95, 98, 98SE, NT 4.0, Me, 2000 Professional, and XP.	Mac OS 8.5 - 9.2.1
32MB or more of RAM (128MB or more with Windows XP)	32MB or more of RAM (64MB or more is recommended)
125MB or more of hard disk space	120MB or more of hard disk space
A monitor with 32000 colors or more	A monitor with 32000 colors or more

PhotoImpression is an application software for still images. To install PhotoImpression, follow the instructions in the read-me folder and installer.

QUICKTIME SYSTEM REQUIREMENTS

IBM PC / AT Compatible
Pentium-based computer
Windows 95, 98, 98SE, NT, Me, or 2000 Professional.
32MB or more of RAM
Sound Blaster or compatible sound card
DirectX 3.0 or later recommended

QuickTime is used for viewing movie clips and playing voice-memo audio files. To install QuickTime, follow the instructions in the read-me folder and in the installer. Macintosh users can download the latest version of QuickTime free of charge from the Apple Computer web site: <http://www.apple.com>.

Camera Notes

To view images correctly on your computer, the monitor's color space may need to be adjusted. Refer to your computer manual on how to calibrate the display to the following requirements: sRGB, with a color temperature of 6500K, and a gamma of 2.2. Changes made to the captured image with the camera's contrast and color-saturation controls will affect any color-matching software in use.

DATA-TRANSFER MODE

CONNECTING THE CAMERA TO A COMPUTER

A fresh set of batteries should be used when the camera is connected to a computer. The use of the AC adapter (sold separately) is recommended over the use of batteries. For users with Windows 98, 98SE, or Mac OS 8.6, read the respective sections on how to install the necessary USB driver before connecting the camera to a computer (Windows 98 - p. 96, OS 8.6 - p. 99).

- 1 Start up the computer.
 - The computer must be turned on before connecting the camera.

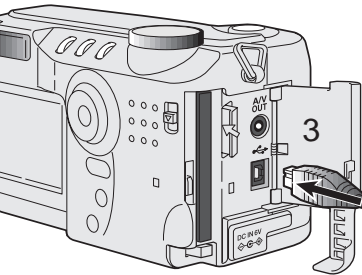

- 2 Insert the CompactFlash card into the camera.
 - Confirm that the correct card is in the camera. To change the CompactFlash while the camera is connected to a computer, see page 104.

- 3 Open the card-slot door. Attach the smaller plug of the USB cable to the camera.
 - Make sure the plug is firmly attached.

- 4 Attach the other end of the USB cable to the computer's USB port.
 - Make sure the plug is firmly attached.
 - The camera should be connected directly to the computer's USB port. Attaching the camera to a USB hub may prevent the camera from operating properly.

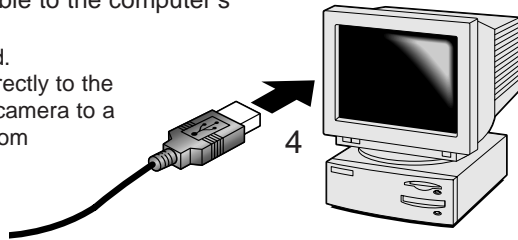

- 5 Set the mode dial to the data-transfer position to initiate the USB connection.

- A screen will appear to indicate the beginning of the connection process. When the signal has been received by the computer, the LCD monitor will turn off.

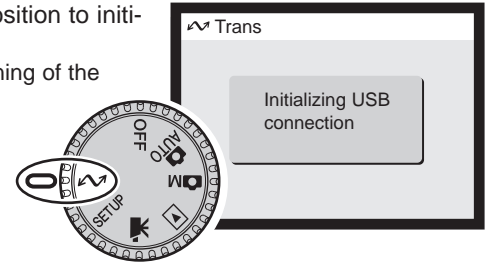

When the camera is properly connected to the computer, a drive icon will appear. When using Windows XP, the removable-disk window will open. If the computer does not recognize the camera, disconnect the camera and restart the computer. Repeat the connection procedure above.

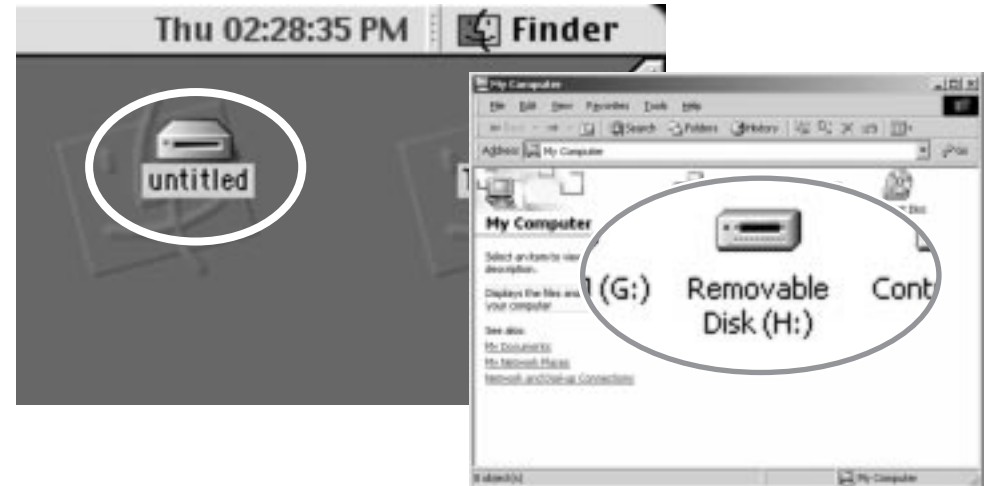

DATA-TRANSFER MODE

CONNECTING TO WINDOWS 98 AND 98SE

The driver needs only to be installed once. If the driver cannot be installed automatically, it can be installed manually with the operating system's add-new-hardware wizard; see the instructions on the following page. During installation, if the operating system requests the Windows 98 CD-ROM, inset it into the CD-ROM drive and follow the accompanying instructions on the screen.

AUTOMATIC INSTALLATION



Before connecting the camera to the computer, place the DiIMAGE software CD-ROM in the CD-ROM drive. The DiIMAGE installer menu should automatically activate. To automatically install the Windows 98 USB driver, click on the starting-up-the-USB-device-driver-installer button. A window will appear to confirm that the driver should be installed; click "Yes" to continue.

When the driver has been successfully installed, a window will appear. Click "OK." Restart the computer before connecting the camera (p. 94).



MANUAL INSTALLATION

To install the Windows 98 driver manually, follow the instructions in the connecting-the-camera-to-a-computer section on page 94.

When the camera is plugged into the computer, the operating system will detect the new device and the add-new-hardware-wizard window will open. Place the DiIMAGE software CD-ROM in the CD-ROM drive. Click "Next."



Choose to specify the location of the driver. The browse window can be used to indicate the driver location. When the location is shown in the window, click "Next."

- The driver should be located in the CD-ROM drive at :\\Win98\\USB.



Choose the recommended search for a suitable driver. Click "Next."



(Continued on the next page)

DATA-TRANSFER MODE



The add new hardware wizard will confirm the location of the driver. Click “Next” to install the driver in the system.

- One of three drivers may be located: MNLVENUM.inf, USBPDR.inf, or USBSTRG.inf.
- The letter designating the CD-ROM drive will vary between computers.

The last window will confirm the driver has been installed. Click “Finish” to close the add new hardware wizard. Restart the computer.



When the my-computer window is opened, a new removable-disk icon will be displayed. Double click on the icon to access the camera's CompactFlash card; see page 100.

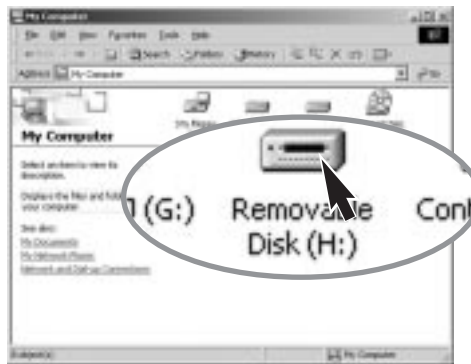

CONNECTING TO MAC OS 8.6

To access this camera with a computer with Mac OS 8.6, the USB storage support 1.3.5.smi must be installed first. This software is supplied by Apple Computer, Inc. free of charge. It can be downloaded from the Apple Software Updates web site at <http://www.apple.com/support>.



USB Storage Support 1.3.5.smi

To download and install this software, follow the instruction on the Apple web site. Always read the attached terms and conditions before installing any new software.

AUTO POWER SAVE (DATA-TRANSFER MODE)

If the camera does not receive a read or write command within ten minutes, it will shut down to save power. When the camera shuts down, an unsafe-removal-of-device warning may appear on the computer monitor. Click “OK.” Neither the camera or computer will be damaged in this operation.

Turn off the camera with the mode dial. Remake the USB connection by turning the mode dial back to the data-transfer position.

DATA-TRANSFER MODE

COMPACTFLASH CARD FOLDER ORGANIZATION



Drive Icon



Misc

The misc. folder contains DPOF print files (p. 78).



Dcim

Image-file names begin with "pict," followed by a four-digit file number, and a tif, jpg, avi, or thm extension. Voice-memo audio files have a wav extension and the file name corresponds to its image file. The thumbnail images (thm) are used in camera operation and cannot be opened.

The last two digits in the folder name indicate the camera that was used to capture the images; "12" indicates a DiIMAGE S404.

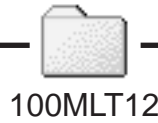

100MLT12



101MLTCP



PICT0001.TIF



PICT0001.THM

Super-fine image



PICT0002.JPG

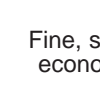

Fine, standard, or economy image



PICT0002.WAV



PICT0002's voice-memo audio file



PICT0003.AVI



PICT0003.THM

Movie clip

Images copied from one CompactFlash to another (p. 80) are placed in a folder with a name ending in "CP." When a new folder is created, the first three digits in the folder name will be one greater than the largest folder number on the card.

Once the camera is connected to the computer, image files can be accessed by simply double clicking on icons. Copying images can be done by dragging and dropping the image-file icon into a location in the computer. Files and folders on the CompactFlash card can be deleted using the computer. Never format the CompactFlash card from the computer; always use the camera to format the card.

The index number on the image file may not correspond to the frame number of the image. As images are deleted on the camera, the frame counter will adjust itself to show the number of images in the folder and reassign the frame numbers accordingly. The index numbers on the image files will not change when an image is deleted. When a new image is recorded, it will be assigned a number one greater than the largest index number in the folder. File numbers can be controlled with the file-number-memory function in the custom 1 section of the setup menu (p. 88).

When the index number in the image file name exceeds 9,999, a new folder will be created with a number one greater than the greatest folder number on the CompactFlash card: e.g. from 100MLT12 to 101MLT12. When a DPOF file is created for a print order (p. 78), a misc. folder is automatically made for the file.

Camera Notes

Image files contain exif tag data. This data includes the time and date the image was recorded as well as the camera settings used. This data can be viewed with the camera or the DiIMAGE Image Viewer utility software.

If a camera image is opened in a photo-retouching application like Arcsoft PhotoImpression, and then the image is saved overwriting the original data, the exif tag information will be erased. When using software other than the DiIMAGE Image Viewer Utility, always rename the image file to protect the exif tag data.

DATA-TRANSFER MODE

DISCONNECTING THE CAMERA FROM THE COMPUTER

Never disconnect the camera when the access lamp is lit - the data or CompactFlash card may permanently be damaged.

WINDOWS 98 AND 98SE

Confirm that the access lamp is not lit. Turn the mode dial to another position and then disconnect the USB cable.

WINDOWS ME, 2000 PROFESSIONAL, AND XP



To disconnect the camera, left click on the unplug-or-eject-hardware icon located on the task bar. A small window will open indicating the device to be stopped.



Click on the small window to stop the device. The safe-to-remove-hardware window will appear. Click "OK." Turn the mode dial to another position and then disconnect the USB cable.



When more than one external device are connected to the computer, repeat the procedure above except right click on the unplug-or-eject-hardware icon. This will open the unplug-or-eject-hardware window after clicking on the small window indicating the device.



On the unplug-or-eject-hardware window, the hardware devices to be stopped will be displayed. Highlight the device by clicking on it then click "Stop."



A confirmation screen will appear to indicate the devices to be stopped. Clicking "OK" will stop the device.

A third and final screen will appear to indicate the camera can be safely disconnected from the computer. Turn the mode dial to another position and then disconnect the USB cable.

MACINTOSH

Confirm that the access lamp is not lit and then drag the mass-storage device icon and drop it into the trash.

Disconnect the USB cable.

- If the USB cable is disconnected before performing the first step, an alert message will appear. Always complete the first step before disconnecting the USB cable.

DATA-TRANSFER MODE

CHANGING THE COMPACTFLASH CARD (DATA-TRANSFER MODE)

Care should be taken when changing CompactFlash cards while the camera is attached to the computer. Data could be lost or damaged if the camera is not properly disconnected.

Always confirm the access lamp is out before removing the CompactFlash card.

WINDOWS 98 AND 98SE

1. Turn off the camera.
2. Change the CompactFlash card.
3. Turn the mode dial to the data-transfer position to remake the USB connection.

WINDOWS ME, 2000 PROFESSIONAL, AND XP

1. Stop the USB connection using the unplug-or-eject-hardware routine (p. 102).
2. Turn off the camera.
3. Change the CompactFlash card.
4. Turn the mode dial to the data-transfer position to remake the USB connection.

MACINTOSH

1. Stop the USB connection by dragging the drive icon into the trash (p. 103).
2. Turn off the camera.
3. Change the CompactFlash card.
4. Turn the mode dial to the data-transfer position to remake the USB connection.

TROUBLESHOOTING

The section covers minor problems with basic camera operation. For major problems or damage, or if a problem continues to reoccur frequently, contact a Minolta service facility listed on the back cover of this manual.

Problem	Symptom	Cause	Solution
The camera will not work.	Nothing displayed on the data panel or the monitors.	The batteries are dead.	Replace batteries (p. 16).
		The batteries are inserted incorrectly.	Reinsert the batteries taking care that the negative and positive terminals are orientated as indicated on the inside of the battery chamber door (p.16).
		The AC adapter is not connected properly.	Check that the adapter is connected to the camera and a live electrical outlet (p. 18).
	The camera was accidentally turned on while in a bag or case, or the lens was hindered while extending.	Turn the camera off and on to restore operation.	
Shutter will not release.	"000" is displayed on the frame counter.	CompactFlash card is full and unable to store an image at the image-quality or image-size setting on the camera.	Insert a new CompactFlash card (p. 18), delete some images (p. 72), or change the image-quality or image-size setting (p. 38, 50).
	No-card warning appears on the monitors.	No CompactFlash card in the camera.	Insert a CompactFlash card (p.18).

TROUBLESHOOTING

Problem	Symptom	Cause	Solution
Pictures are not sharp.	Focus signal is red.	Subject is too close.	Make sure the subject is within the autofocus range (p. 24) or use the macro mode (p. 28).
		The camera is in macro mode.	Cancel the macro mode setting (p. 28).
	A special situation is preventing the autofocus system from focusing (p.25)	Use the focus-lock function to focus on an object at the same distance as the subject (p. 24) or use manual focus (p. 56).	
Pictures are taken indoors or in low-light situations without flash.	Slow shutter speeds result in blurred images when the camera is hand-held.	Use a tripod, change the camera sensitivity to a higher setting (p. 50), or use the flash (p. 30).	
Continuous drive does not work.	The image quality is set to super fine.		Change the image-quality setting (p. 38, 50).
While using flash, the pictures are too dark.		The subject is beyond the flash range (p. 57).	Move closer to the subject or change the camera sensitivity to a higher setting (p. 50).
“Err” displayed on the data panel.	Turn off the camera and remove the batteries or unplug the external power supply. Wait for the message to disappear before reinserting the batteries or plugging in the power supply. If the camera is hot, allow it to cool before removing the batteries and Compactflash card.		

Problem	Symptom	Cause	Solution
Shooting data is displayed, but live image is entirely black or white.	Camera set to manual-exposure mode (M).	Shutter speed and aperture combination is extremely under or over-exposing the live image.	Change the shutter speed or aperture value until an image appears on the monitor (p. 53).

If the camera does not function normally, turn it off, remove and reinsert the batteries, or unplug and reconnect the AC adapter. Always turn the camera off using the mode dial otherwise the CompactFlash card may be damaged and camera settings reset.

The camera temperature rises with extended periods of use. Care should be taken to avoid burns when handling the camera, batteries, or CompactFlash card.

ABOUT NI-MH BATTERIES

When using Ni-MH batteries, clean both battery terminals with dry cloth to wipe off any dirt or residue. Because of the sophisticated computer system, the camera critically monitors power levels. If the battery terminals are dirty, the camera may give a false low-battery warning. If battery performance is unusually low, wipe the battery terminals with a clean, dry cloth.

Ni-MH battery performance will decrease if the batteries are often recharged before they have been fully discharged. Completely exhaust the Ni-MH batteries using the camera before charging.

Removing the driver software - Windows

1. Insert a memory card in the camera and connect it to the computer with the USB cable. Other devices must not be connected to the computer during this procedure.

2. Right click on the My-computer icon. Select “properties” from the drop-down menu.

Windows XP: from the start menu go to the control panel. Click on the performance and maintenance category. Click “System” to open the system properties window.

3. Windows 2000 and XP: select the hardware tab in the properties window and click the device-manager button.

Windows 98 and Me: click the device-manager tab in the properties window.

4. The driver file will be located in the universal-serial-bus-controller or other-devices location of the device manager. Click on the locations to display the files. The driver should be indicated with the camera name. Under certain conditions, the driver name may not contain the camera name. However, the driver will be indicated by either a question mark or exclamation point.

5. Click on the driver to select it.

6. Windows 2000 and XP: click on the action button to display the drop-down menu. Select “uninstall.” A confirmation screen will appear. Clicking “Yes” will remove the driver from the system.

Windows 98 and Me: click the remove button. A confirmation screen will appear. Clicking “Yes” will remove the driver from the system.

7. Disconnect the USB cable and turn off the camera. Restart the computer.

CAMERA CARE

- Do not subject the camera to shock or impact.
- Turn off the camera when transporting.
- This camera is neither waterproof nor splashproof. Inserting or removing batteries or the CompactFlash card, or operating the camera with wet hands may damage the camera.
- When at the beach or near water, take care not to expose the camera to water or sand. Water, sand, dust, or salt can damage the camera.
- Do not leave the camera under direct sunlight. Do not point the lens directly at the sun; the CCD may be damaged.

CLEANING

- If the camera or the outside of the lens is dirty, gently wipe it with a soft, clean, dry cloth. If the camera or lens comes in contact with sand, gently blow away loose particles. Wiping may scratch the surface.
- To clean the lens surface, first blow away any dust or sand, then, if necessary, moisten a lens tissue or soft cloth with lens cleaning fluid and gently wipe the lens.
- Never use organic solvents to clean the camera.
- Never touch the lens surface with your fingers.

STORAGE

- Store in a cool, dry, well-ventilated area away from dust and chemicals. For long periods of disuse, store the camera in an airtight container with a silica-gel drying agent.
- Remove the batteries and CompactFlash card from the camera when not in use for extended periods.
- Do not store the camera in an area with naphthalene or mothballs.
- During long periods of storage, operate the camera occasionally. When taking the camera out of storage, check that the camera is functioning properly before using.

CARE AND STORAGE

OPERATING TEMPERATURES AND CONDITIONS

- This camera has been designed for use in temperatures from 0°C to 40°C (32°F to 104°F).
- Never leave the camera exposed to extreme high temperatures, such as in a car parked in the sun, or to extreme humidity.
- When taking the camera from a cold to a warm environment, place it in a sealed plastic bag to prevent condensation from forming. Allow the camera to come to room temperature before removing it from the bag.

COMPACTFLASH CARD CARE AND HANDLING

- The following may cause data loss or damage.
 - 1 Improper use of the card.
 - 2 Static electrical discharge or electromagnetic fields near the card.
 - 3 Removing the card or interrupting the power supply while the camera or computer is accessing the card (reading, writing, formatting, etc.).
 - 4 The disuse of a card for an extended period.
 - 5 Using the card beyond its life
- **Minolta has no responsibility for any loss or damage to data.** It is recommended that a copy of the card data be made in another media such as a ZIP disc, hard disk, CD-ROM, etc.
- When the card is formatted, all recorded data will be deleted. Be sure to make a backup of any important data.
- The storage capability of the CompactFlash card will diminish with extended use. It may be necessary to purchase a new card periodically.
- Keep away from static electricity and electromagnetic fields.
- Do not bend, drop, or subject the card to impact.
- Strong static electrical discharges or physical shock may prevent the card from being able to transfer data.
- Do not touch the electrical contacts of the card with your fingers or metal objects.
- Keep away from heat, moisture, and direct sunlight.
- Keep away from small children.

BATTERIES

- Battery performance decreases with temperature. In cold environments, we recommend keeping spare batteries in a warm place, such as the inside of a coat. Batteries can recover their power when they warm up. As the performance of Ni-MH batteries are less affected by temperature, their use is recommended when shooting in cold environments.
- Remove the batteries when the camera is not in use for an extended period. Leaking battery fluid may damage the battery-chamber.
- Occasionally, when using alkaline batteries, the battery-condition indicator will give a false low-battery-power warning, even though there is enough power capacity. Continue to use the camera; the low-battery indicator will disappear.
- If batteries have been exhausted when used in the camera, do not reload them even if their charge seems to recover over time. These batteries will interfere with normal camera operation.

LCD MONITOR CARE

- Although the LCD monitor is manufactured using high precision technology, there may occasionally be a lack of color or bright points on the LCD monitor.
- Do not apply pressure to the surface of the LCD monitor; it may be permanently damaged.
- In a cold environment, the LCD monitor may become temporarily dark. When the camera warms up, the display will function normally.
- The LCD monitor may be slow to react in low temperatures or may turn dark in a hot environment. When the camera reaches normal operating temperature, the display will function normally.
- If fingerprints are on the LCD monitor surface, gently wipe with a soft, clean, dry cloth.

COPYRIGHT

- TV program, films, video tapes, photographs, and other materials may be copyrighted. Unauthorized recording or duplication of such material may be contrary to copyright laws. Taking pictures or images of performances, exhibitions, etc., is prohibited without approval and can infringe on copyright. Images protected by copyright can only be used under the provisions within the copyright laws.

CARE AND STORAGE

BEFORE IMPORTANT EVENTS OR JOURNEYS

- Check the camera's operation; take test pictures and purchase spare batteries.
- Minolta has no responsibility for any damage or loss incurred by equipment malfunction.

QUESTIONS AND SERVICE

- If you have questions about your camera, contact your local camera dealer or write to the Minolta distributor in your area.
- Before shipping your camera for repair, please contact a Minolta Service Facility.

The following marks may be found on the product:



This mark certifies that this camera meets the requirements concerning interference causing equipment regulations in Japan.



This mark on your camera certifies that this camera meets the requirements of the EU (European Union) concerning interference causing equipment regulations. CE stands for Conformité Européenne (European Conformity).

Digital Camera: DiIMAGE S404



Tested To Comply
With FCC Standards

FOR HOME OR OFFICE USE

This device complies with Part 15 of the FCC Rules. Operation is subject to the following two conditions: (1) This device may not cause harmful interference, and (2) this device must accept any interference received, including interference that may cause undesired operation.

Tested by the Minolta Corporation
101 Williams Drive, Ramsey, New Jersey 07446, U.S.A.

This Class B digital apparatus complies with Canadian ICES-003.

Cet appareil numérique de la classe B est conforme à la norme NMB-003 du Canada.

Do not remove the ferrite cores from the cables.

Apple, the Apple logo, Macintosh, Power Macintosh, Mac OS, and the Mac OS logo are registered trademarks of Apple Computer Inc. Microsoft and Windows are registered trademarks of the Microsoft Corporation. The official name of Windows® is Microsoft Windows Operating System. Pentium is a registered trademark of the Intel Corporation. PhotoImpression is a trademark of ArcSoft, Inc. Power PC is a trademark of the International Business Machines Corporation. QuickTime is a trademark used under license. All other trademarks are the property of their respective owners.

TECHNICAL SPECIFICATIONS

Number of effective pixels:	3.95 million
CCD:	1/1.8-type interline primary-color CCD with a total of 4.13 million pixels.
Camera sensitivity (ISO):	Auto and 64, 100, 200, and 400 ISO equivalents.
Aspect ratio:	4:3
Lens construction:	11 elements in 9 groups including one AD glass and two double-sided aspheric elements.
Maximum aperture:	f/3.0 (wide-angle position), f/3.6 (telephoto position)
Focal length:	7.15 - 28.6 mm (35mm equivalent: 35 - 140 mm)
Focusing range (from the CCD):	0.5 m - infinity (wide-angle position) 0.9 m - infinity (telephoto position) 0.16 - 0.6 m in macro mode
Filter diameter:	35.5 mm
Autofocusing system:	Video AF
Shutter:	CCD electronic shutter plus mechanical shutter
Shutter speeds:	1/1000 - 4s, bulb (15s maximum)
Built-in flash recycling time:	8s (approx)
Viewfinder:	Optical real-image zoom viewfinder.
Monitor LCD:	46 mm TFT color
Monitor field of view:	Approximately 100%
A/D conversion:	12 bits
Recording media:	Type I CompactFlash cards
File formats:	Exif 2.1 (JPEG, TIFF), motion JPEG (avi), WAV. DCF 1.0 and DPOF compliant.
Print Image Matching:	Yes
Menu languages:	Japanese, English, German, French, and Spanish
Video output:	NTSC and PAL

Batteries:	4 AA Ni-MH or alkaline batteries. Ni-MH batteries are recommended over alkaline.
Battery performance (recording):	Approximately 150 frames: based on Minolta's standard test method: 1,600mAh Ni-MH batteries, LCD monitor on, full-size images (2272 X 1704), standard image quality, no instant playback, no voice memo, flash used with 50% of the frames. Approximately 280 frames: based on Minolta's standard test method: 1,600mAh Ni-MH batteries, LCD monitor off, full-size images (2272 X 1704), standard image quality, no instant playback, no voice memo, flash used with 50% of the frames.
Battery performance (playback):	Approx. continuous playback time: 110 min. Based on Minolta's standard test method: 1,600mAh Ni-MH batteries, LCD monitor on.
External power source:	AC adapter (AC-1L or AC-2L) High-power battery pack (EBP-100)
Dimensions:	113.5 (W) X 64.5 (H) X 58.5 (D) mm
Weight:	Approximately 335g (without batteries or CompactFlash card)
Operating temperature:	0° - 40°C
Operating humidity:	5 - 85% (noncondensing)

Specifications are based on the latest information available at the time of printing and are subject to change without notice.

MINOLTA

Minolta Co., Ltd.

3-13, 2-Chome, Azuchi-Machi, Chuo-Ku, Osaka 541-8556, Japan

Minolta Corporation

Head Office

101 Williams Drive, Ramsey, New Jersey 07446, U.S.A.

Los Angeles Branch

11150 Hope Street Cypress, CA 90630, U.S.A.

Minolta Canada Inc.

369 Britannia Road East, Mississauga, Ontario L4Z 2H5, Canada

Minolta Europe GmbH

Minoltaring 11, D-30855 Langenhagen, Germany

Reparatur/Repair

Senator-Helmken-Strasse 1, D-28197 Bremen, Germany

Minolta France S.A.

365 Route de Saint-Germain, F-78420 Carrieres-Sur-Seine, France

Minolta (UK) Limited

7 Tanners Drive, Blakelands, Milton Keynes, MK14 5BU, England

Minolta Austria Ges. m.b.H.

Amalienstrasse 59-61, A-1131 Wien, Austria

Minolta Camera Benelux B.V.

Zonnebaan 39, P.O. Box 6000, NL-3600 HA Maarssen, The Netherlands

Belgian Branch

Prins Boudewijnlaan 1, B-2550 Kontich, Belgium

Minolta (Schweiz) AG

Riedstrasse 6, CH-8953 Dietikon, Switzerland

Minolta Svenska AB

Albygatan 114, S-171 54 Solna, Sweden

Finnish Branch

Niittykatu 6 PL 37, SF-02201 Espoo, Finland

Minolta Portugal Limitada

Av. do Brasil 33-A, P-1700 Lisboa, Portugal

Minolta Hong Kong Limited

Room 208, 2/F, Eastern Center, 1065 King's Road, Quarry Bay, Hong Kong

Minolta Singapore (Pte) Ltd.

10, Teban Gardens Crescent, Singapore 608923

© 2002 Minolta Co., Ltd. under the Berne Convention
and the Universal Copyright Convention.